

THE PISTON EFFECT TEST BENCH FOR THE GRAND PARIS EXPRESS

¹Elisa BERAUD, ¹Fabien JOUVE, ¹Benoît HOUSEAUX

¹Eiffage Énergie Systèmes, Ventilation of tunnel & underground spaces

ABSTRACT

The "Grand Paris Express" railway network is currently under construction. It has been very quickly predicted that piston effect created by train will be greater than the traditional Parisian metropolitan network and all other networks in the world. This piston effect will be reflected in the stations and in all the shafts positioned roughly every 800 m in the tunnels for the intervention of emergency services.

These shafts are also used for ventilation for passenger comfort and safety. As a consequence, the equipment in the shafts will face with piston effect and will be subjected to strong variations in pressure. At reduced fan speed, it is expected the fans will be passed through with a negative airflow and also operated in negative pressure. Therefore, they will be operated in areas that are not defined by the usual.

In order to characterize a "Grand Paris Express" type fan, Eiffage carried out a platform to test the behavior of a model fan to the train piston effect. This test bench has been designed to reproduce the train passage on a cycle representative of the estimated pressure variation. The fan is therefore operated with successive negative and positive forced pressure on hundreds of thousands of cycles to ensure the durability of the equipment on several years of operation.

Keywords: metro tunnel, train piston effect, test bench, model fan

INTRODUCTION

The new Grand Paris Express (GPE) railway network differs from the traditional Parisian metropolitan network for several combined reasons. On the one hand, the infrastructure is constituted of a succession of 1,000-2,000 m single bore bidirectional tunnels and stations with optimized sections of 50 m² and, on the other hand, it is operated with trains that travel at 110 km/h with a frequency passage of 90 s in rush hours.

It is expected the piston effect created by the overpressure due to the mass of air pushed in front the train and by the depression created behind the train would be exceptional in the tunnels: about $\pm 1,000$ Pa in a few seconds.

The piston effect would be specific to each part of the lines depending of interdistance between stations, the slope and the curve of the track giving accelerating and braking behavior of the trains.

Piston effect would be also a function of train rate depending of peak hours (8:00 to 10:00 am then 5:00 to 8:00 pm) and off-peak hours (the rest of the day) or during weekend with a frequency passage of several minutes.

The following figure gives an illustration of the total pressure in the tunnel during the passing of two carousels of 10 trains spaced 90 s apart:

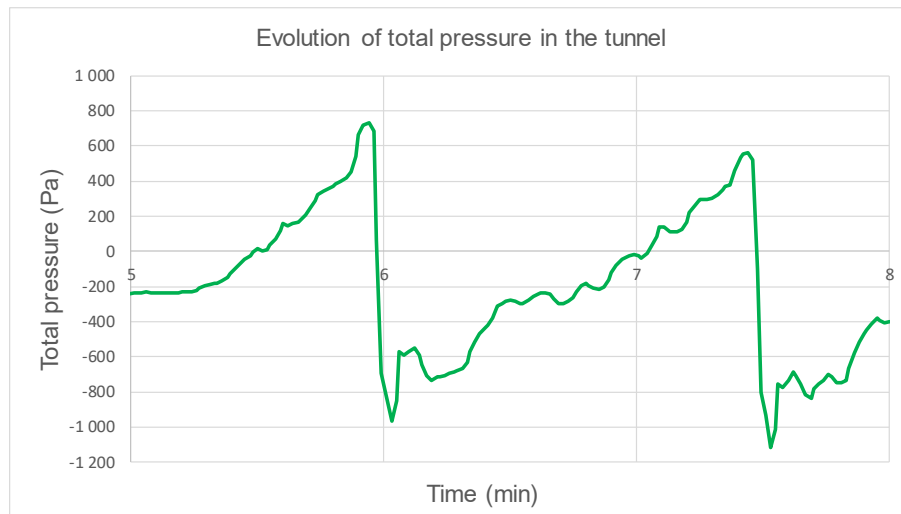

Figure 1: the evolution of total pressure in the tunnel (calculated by 1D code)

For the studies, the piston effect of Grand Paris Express has been characterized as follow:

- A criterion of total pressure of + 900 Pa and – 1400 Pa (conservative);
- A criterion of pressure gradient that is:
 - A decrease in pressure of 2,100 Pa at a rate of decrease of up to -500 Pa/s,
 - An increase in pressure of 1,600 Pa at a rate of up to 450 Pa/s.

These pressure fluctuations are reflected in the ventilation shafts located between the stations where the ventilation equipment is installed. And this at each train passage.

As a consequence, they are subjected to strong variations in pressure, which will modify the operating points. Therefore, they could be operated in areas of negative pressure and / or negative flow rates that are not defined for fans. With each passage of trains, the fans could be taken to unexplored operating zones.

We were aware that the consequences could be dramatic for operation: the fans could explode quickly after commissioning and would cause restrictions (or closure) of lines while operating.

Therefore, these new operating zones had to be explored. Several tests have been carried out with manufacturer to characterize the behaviour of the fan in the three quadrants of the curve (including negative flow and negative pressure) according to international standards (AMCA 802 and NF EN ISO 5801).

Then the endurance and resistance of the fans to these stresses had to be assessed. That is why a test bench has been designed, developed and build on Eiffage site to study the piston effect on a test fan which is similar but in smaller scale to the fans installed in Grand Paris Express shafts. Continuous operation of the bench makes it possible to simulate the operation of the real fan over several years and to test its durability.

The paper is more specific about the test bench (the description and characterisation of the model fan can be found in [4]). After a brief presentation of piston effect on GPE network, the paper will present the design of the test bench. Then it will present the principle of the test to reproduce the piston effect on the model fan.

THE GRAND PARIS EXPRESS METRO

The network

Grand Paris Express (GPE) will be a 100% automatic metro system of the Capital Region in France [1]. With its 68 brand new interconnected stations and 200 kilometers of new railway lines, this transit network will consist of a ring route around Paris (line 15) and lines connecting developing neighborhoods (lines 16, 17 and 18). Additionally, Grand Paris Express will also involve the extension of existing metro lines (line 14 to South). They will provide connections with Paris' airports, business districts and research clusters. It will service 165,000 companies and daily transport 2 million commuters.

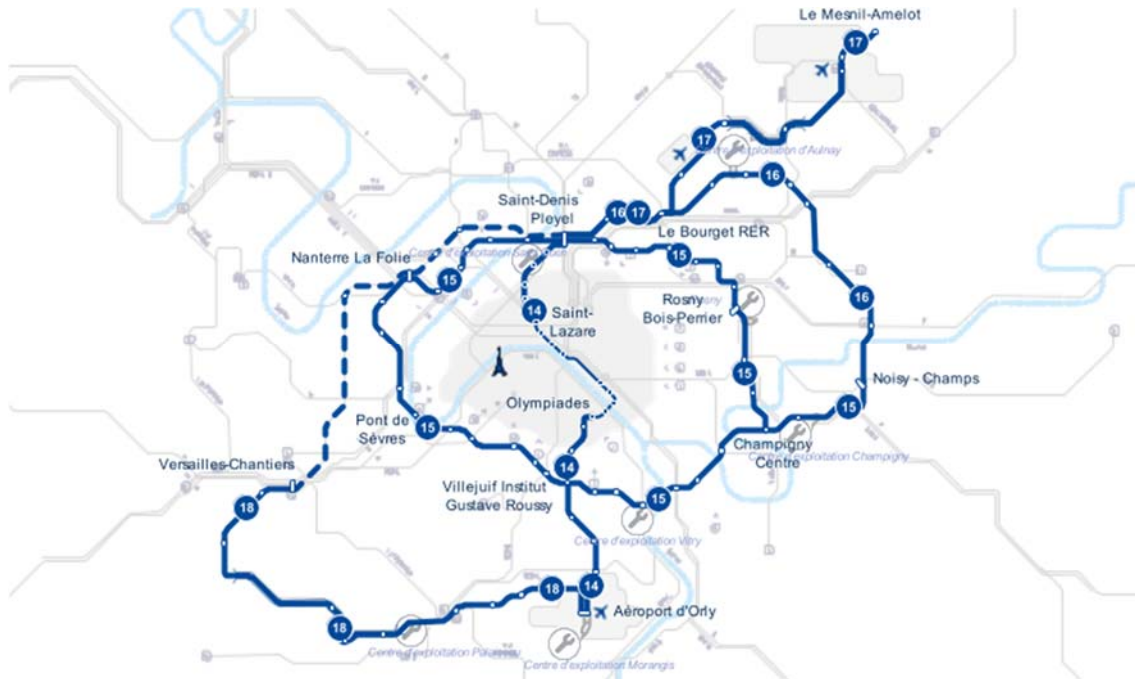

Figure 2: Grand Paris Express network

With 90 % of lines built underground, the good functioning of the new metro is ensured by the essential “service structure” positioned between stations.

Three times more numerous than stations, the 160 service structures will combine several functions, in particular related to passenger comfort and safety. Especially 120 of them will be equipped by ventilation equipment first to control smokes and protect the stations in case of fire in the tunnel, then to ensure air quality in the tunnel.

The ventilation system

The design of the Grand Paris Express ventilation system must comply with the regulation of 22 November 2005 related to safety in tunnels of metros. [2]

As often, the ventilation system is sized by smoke extraction.

In the tunnel of GPE, the spread of smoke to facilitate evacuation of users and intervention of emergency services is controlled by a push-pull system. [3] It consists of using adjacent ventilation shafts in supply and/or extraction to ensure a distribution of the flows satisfying requested velocities.

To generate a velocity greater than 1.5 m/s upstream of the fire and a containment velocity of 0.5 m/s, the extraction smoke airflow in the tunnel is evaluated at 150 m³/s.

In operation, the comfort of passenger and air quality of tunnels is ensured by natural ventilation and reinforced during rush hours by mechanical ventilation working at reduced speed. The airflow is sized at 75 m³/s.

For this running point, fan are extremely sensitive to piston effect.

THE PISTON EFFECT ON FAN

This last point can be illustrated on the operating curve of the fan (see Fig. 3).

The fans that will be installed by Eiffage in the ventilation service structures of lines 15 South, 16 and 17 of GPE are from Howden. The model ANR-2371/1122 will allow an operation for both fire extraction mode (operating point 1) and normal mode ventilation (operating point 2).

In case of fire, the fan will generate a flowrate of 150 m³/s and counter a network resistance of 1,200 Pa. The operating point is represented in red. In normal mode, the fan will work half speed and will generate a flowrate of 75 m³/s for a total pressure of 300 Pa. The operating point is represented in blue.

Resistance is the green line. The effect of train arriving (overpressure of + 900 Pa in the tunnel experienced as decrease of 900 Pa for the fan) and train leaving (depression of – 1,400 Pa in the tunnel) is represented with the two green dotted lines.

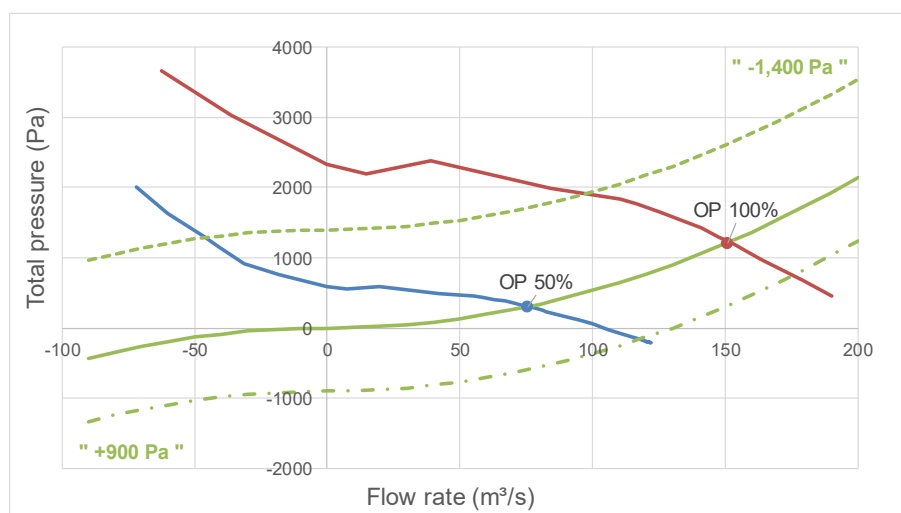

Figure 3: the piston effect on fan operation

The blue curve at reduced speed shows the displacement on the operating curve implying the need for anti-stall treatment. At the maximum pressure point (+ 1,400 Pa), the fan will be passed through with a negative airflow even though the fan is still running the same direction.

Extrapolation of the blue curve with the network curve for a tunnel pressure of + 900 Pa suggests that the two curves would intersect in negative pressure. This implies *a priori* the operation of the motor as a generator (negative mechanical power).

It appeared the fans would be taken in operating zones never encountered. As a consequence, they have to be characterized in these zones and then operated to test their resistance and durability with strong pressure variations.

It would not worth to test the piston effect on a real fan. It would take place and use a lot of power to be fully representative of the phenomenon. With a similitude of Reynolds and with same constraints on blades (with about the same tip velocity), the consequences of piston effect (both in the thresholds and in the pressure gradients) can be characterized on a model fan.

Common sense and scale consideration led Eiffage to carry out the tests on a fan with a diameter of 1,000 mm. This model fan has been installed on a test bench we designed and build - and then used - to reproduce the phenomenon of piston effect.

THE TEST BENCH

The test bench is made up of a circuit in which are inserted the model fan and a generator fan which makes it possible to impose a pressure (or train passage) in this circuit.

The model fan can be forced with flow in one direction or the other by means of a dampers system, thus making it possible to simulate the effect of alternative overpressure and depression that are identical to the one encountered in real size.

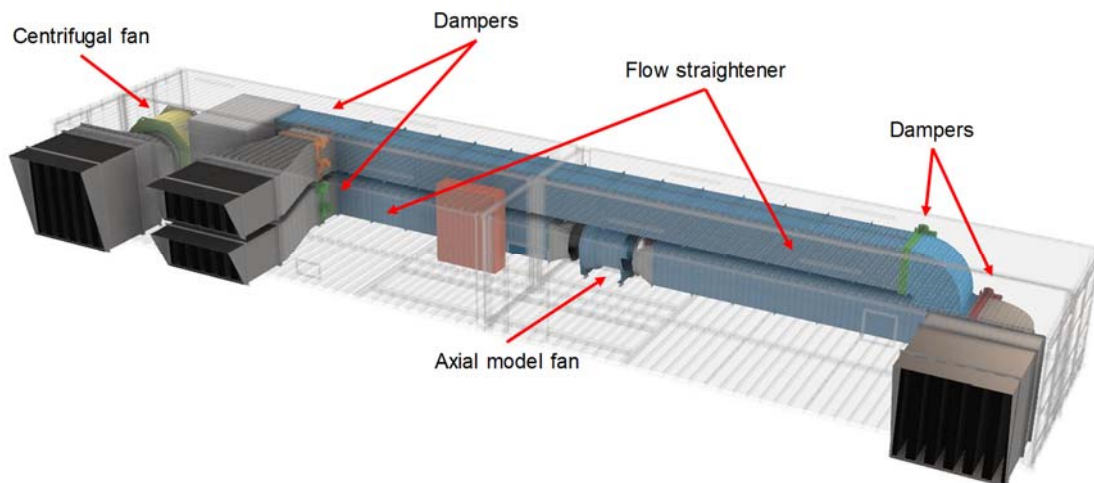

Figure 3: The test bench (front view)

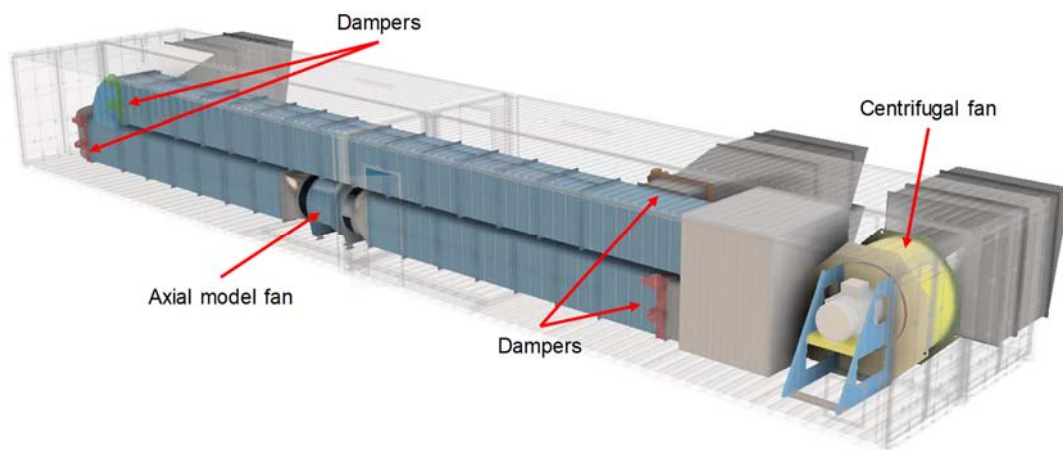

Figure 4: The test bench (behind view)

More precisely, the test bench has the size of 4 x 40 ft. containers (see Fig. 3 and 4).

The circuits are 1m x 1m metal ducts. Grids (or “flow straightener disposal”) have been added in upper part and lower part of circuits to reduce swirl and homogenize the flow in the ducts (according to standards NF EN ISO 5801).

The model fan is a 37 kW ANR-1000/473 axial fan, where both geometric and dynamic similarity have been respected with the full size fan installed in the GPE shafts. [4]

The following table gives the scaling and operating points of the model fan.

Table 1: real size and model fan characteristics

	Real size	Model
Impeller diameter	2,371 mm	1,000 mm
Hub diameter	1,122 mm	473 mm
Operating point 1		
Airflow	150 m ³ /s	26.7 m ³ /s
Total pressure	1,200 Pa	1,200 Pa
Rotation speed	980 rpm	2,324 rpm
Operating point 2		
Airflow	75 m ³ /s	13.3 m ³ /s
Total pressure	300 Pa	300 Pa
Rotation speed	490 rpm	1,162 rpm

The model fan will always rotate at the same speed and in the same direction (with a shaft power of about 5.5 kW) and would generate a flow from left to right on the test bench (Fig. 3).

The generator fan is a 75 kW centrifugal fan with an impeller diameter of 1,250 mm that produces 25 m³/s for a pressure difference of 1,800 Pa. It will be operated at constant speed and constant power (about 70 kW).

Air flow is sucked from outside by the 2m x 2m portal on the left; it is rejected in a plenum of 2m high, 1m large and 2m long. Then airflow is oriented in one or other ducts.

When the dumper in the top ducts are closed, the flow circulates in the bottom 1m x 1m ducts and evacuates outside by the 2m x 2m portal on the right (Fig. 3). The model fan is passed through with a flow in the same direction. This is operation in positive direction (see Fig. 5). The pressure is imposed by means of the flow rate. On the operation curve, the point is displaced in the negative pressure zone as if the train was arriving. The fan receives works as a generator.

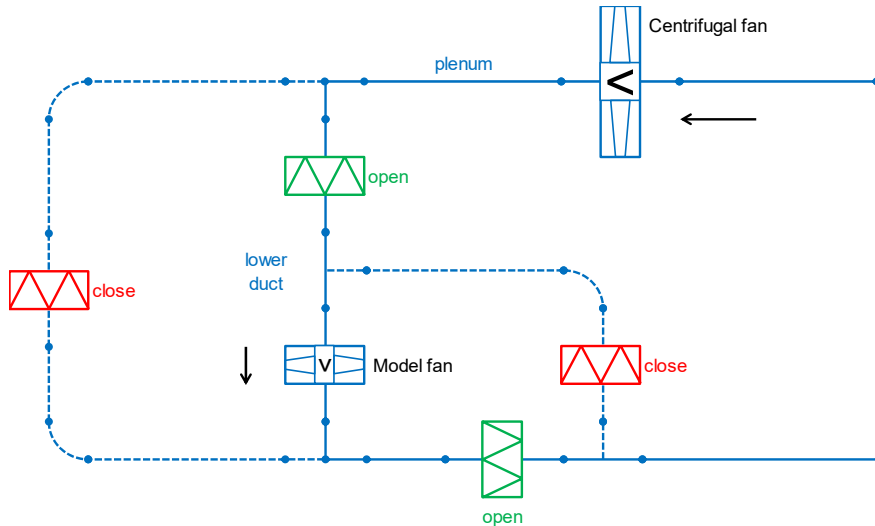

Figure 5: Operation in positive direction

When the dumper in the bottom ducts are closed, the flow circulates in the top 1m x 1m ducts, comes back in the bottom ducts, and evacuates outside by the 2m x 1m bottom portal on the middle (Fig. 3). The model fan is passed through with a flow in the opposite direction. This is operation in negative direction (see Fig. 6). On the operation curve, the point is displaced in the negative airflow zone as if the train was leaving. The fan generates a flow in one direction and receives a flow in opposite direction. The fan is under high pressure.

As the need to bring fan in negative airflow is less important, there is a discharge regulated by a damper in the plenum through the 2m x 1m top portal on the middle (Fig. 3 and 4).

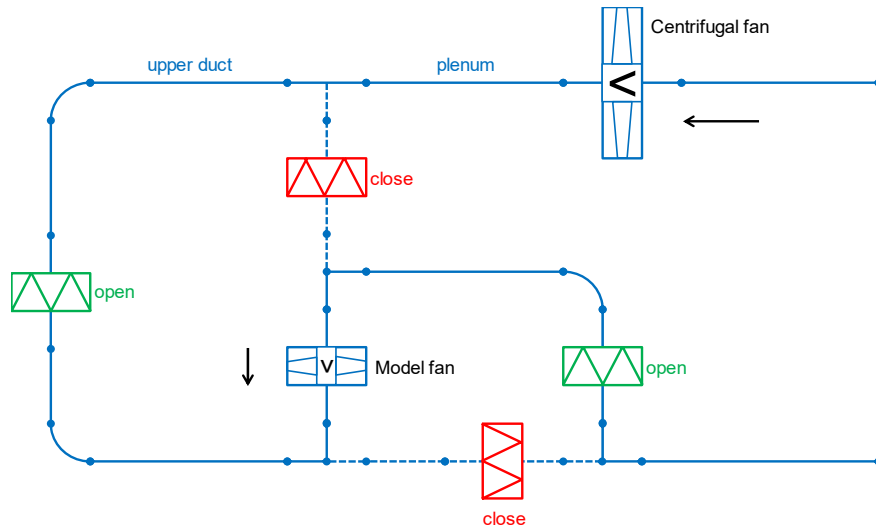

Figure 6: Operation in negative direction

The test bench can be operated alternatively in negative pressure and negative airflow to simulate passage of trains with a programmed sequence of dampers. Opening and closing have been adjusted to simulate the pressure gradient of arriving and departing train but have been accelerated to concatenate frequency of passage.

They can be opened or closed in 2 seconds; the kinetics can be determined and intermediate position can be ordered (see Fig. 7). Dampers are operated with 4-20 mA. An example of opening and closing curves of dampers can be illustrated on Fig. 7.

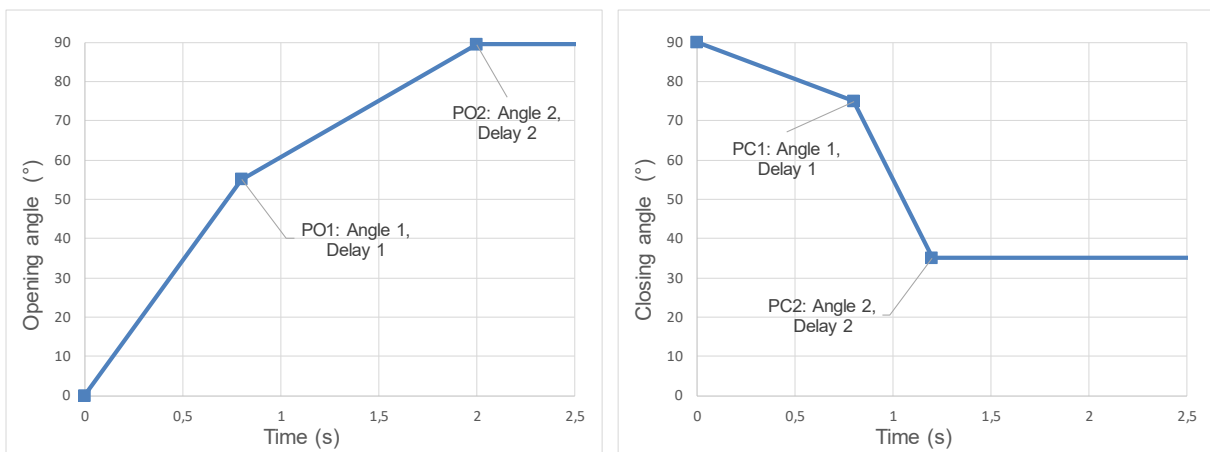

Figure 7: Opening and closing of dampers

Instrumentation

The test bench is equipped with many captors. On each upper and lower ducts of the circuit, there at least two means of airflow determination, which could be:

- Vane anemometers;
- Static pressure probes;
- Measurement wings.

There are three anemometers: one is placed in the upper duct to measure airflow upstream the fan when operated in negative direction and the two others are in the lower duct to measure airflow upstream and downstream the fan when operated in positive direction.

Flow is also measured with pressure probes in the area of the model fan impeller and the flow straighteners. Moreover, we have placed a measurement damper (a classic damper whose blades are fitted with pressure taps) that allow to determine the flow through the duct. [5]

The bench has been calibrating with Pitot probe measurement on 36 vertical and horizontal points on a section with log-Tchebycheff distribution (according to NF EN ISO 5802). All the sections close to anemometers have been tested. In parallel, the “dzeta” or pressure drop coefficient of the disposal has been determined.

The fan is of course equipped with vibration captors. Temperature bearings and windings are also measured. All data are send to SCADA cabinet and registered to be analyzed.

The test bench can be automatically operated (train passage cycle) for endurance tests. All equipment can also be separately and manually operated. Under these conditions, the fan can be operated stationary in all configurations.

CONCLUSION

The train piston effect that fan installed in the ventilation shafts of the Grand Paris Express network will endure is currently studied on a homothetic model fan.

The model fan has been first characterized by manufacturer for the specified operating points in smoke extraction mode and normal mode. It has also to be tested at negative pressure and negative flow, both in forward and reverse direction. [4]

Then the model fan has been installed and operated on the test bench designed by Eiffage to simulate the train piston effect. The model fan has been yet operated over 300,000 cycles of train passages, which can be equivalent to an operation over more than 10 years.

The test bench has allowed to test the resistance and the durability of the fan submitted to pressure variations with very strong pressure gradients both positive and negative over a very short time interval. At the end of the test, the blades will be tested to study and verify mechanical fatigue the fan has endured.

The bench has allowed to test the behavior of the fan with significant airflow disturbances in operation. It has been experienced especially in extreme configuration of train passage: with the train adding a flow to the flow of the fan (fan as a wind turbine) or with the train imposing a flow in the opposite direction the fan is operating.

REFERENCES

- [1] <https://www.societedugrandparis.fr>
- [2] Arrêté du 22 Novembre 2005 relatif à la sécurité dans les tunnels des systèmes de transport public guidés urbains de personnes
- [3] Ventilation et désenfumage des réseaux de métro, P. Carlotti, J.-F. Burkhart, A. Mos, A. Dusserre and J.-M. Passelaigue, Techniques de l'Ingénieur, March 2022
- [4] A model fan to test the train piston effect at Grand Paris Express metro, E. Béraud, B. Houseaux, F. Duet, FAN 2022, Senlis (France), 27 – 29 June 2022
- [5] The measurement damper tested and validated in the B5 ramp, E. Béraud, V. Jury, B. Houseaux, J.P. Margrita, ISAVFT 2022, Brighton (UK), 28 – 30 Sept 2022