

Schnitt A-B.
Fig. 96 a.

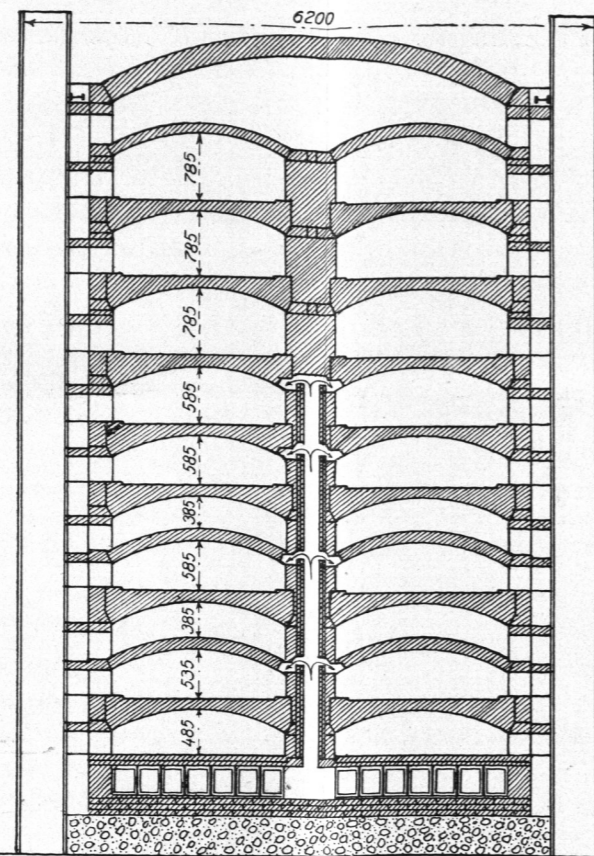

Schnitt C-D.
Fig. 96 b.

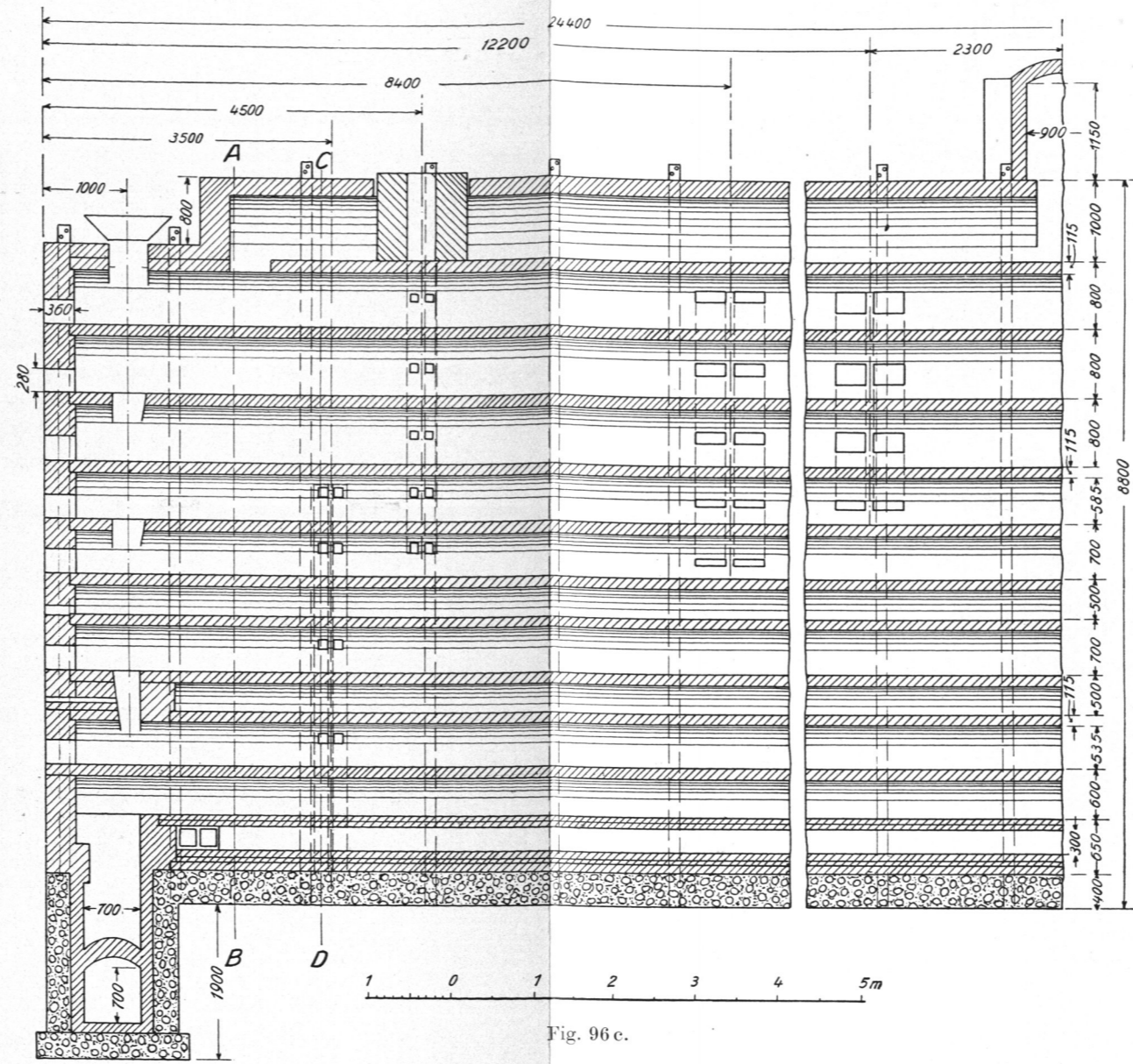

Fig. 96 c.

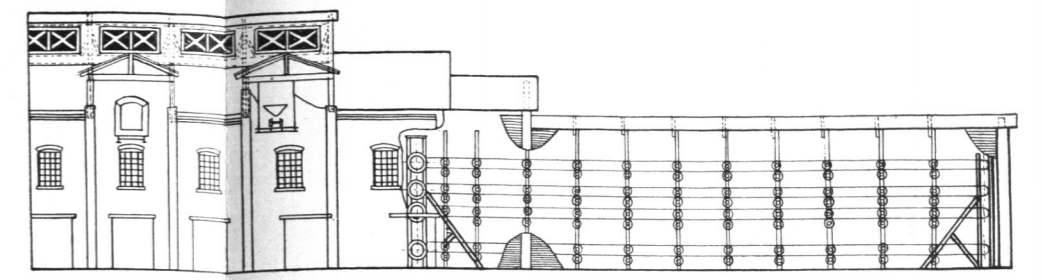

Fig. 96 f.

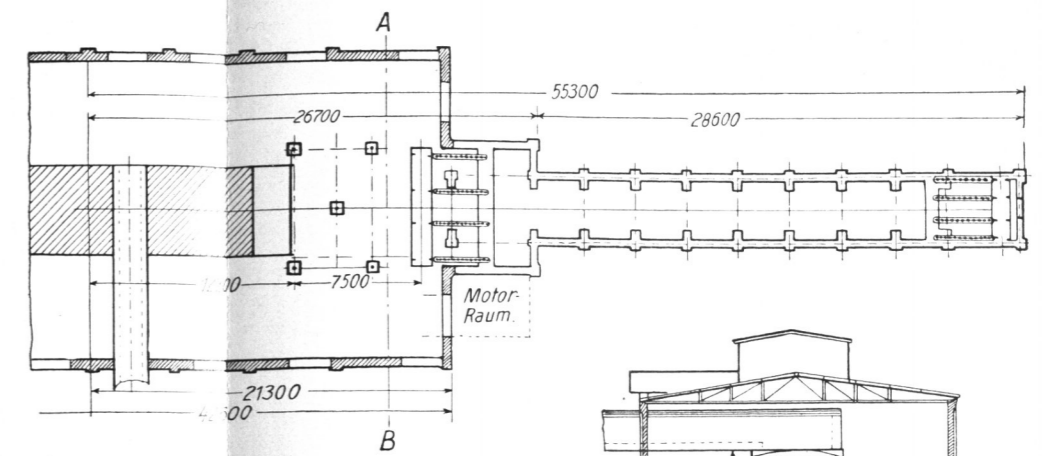
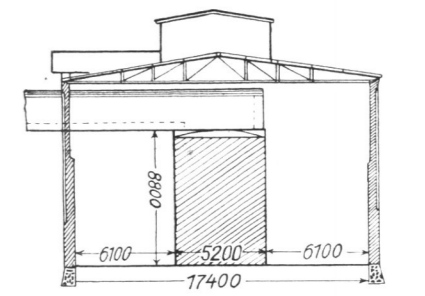

Fig. 96 d.



Schnitt A-B.
Fig. 96 e.

Fig. 96a—f. Hegeler-Ofen. Nach Liebig, Zink u. Cadmium. — 96 a. Querschnitt A—B; 96 b. Querschnitt C—D; 96 c. Längsschnitt durch das Beschickungsende; 96 d. Grundriß des Ofenhauses; 96 e. Querschnitt durch das Ofenhaus; 96 f. Aufsicht des Ofenhauses. — Maße in mm.