

1 B, Sächs. Staatsbahn.

Verschiedene Erbauer 1853.

Durchhängende Büchse.

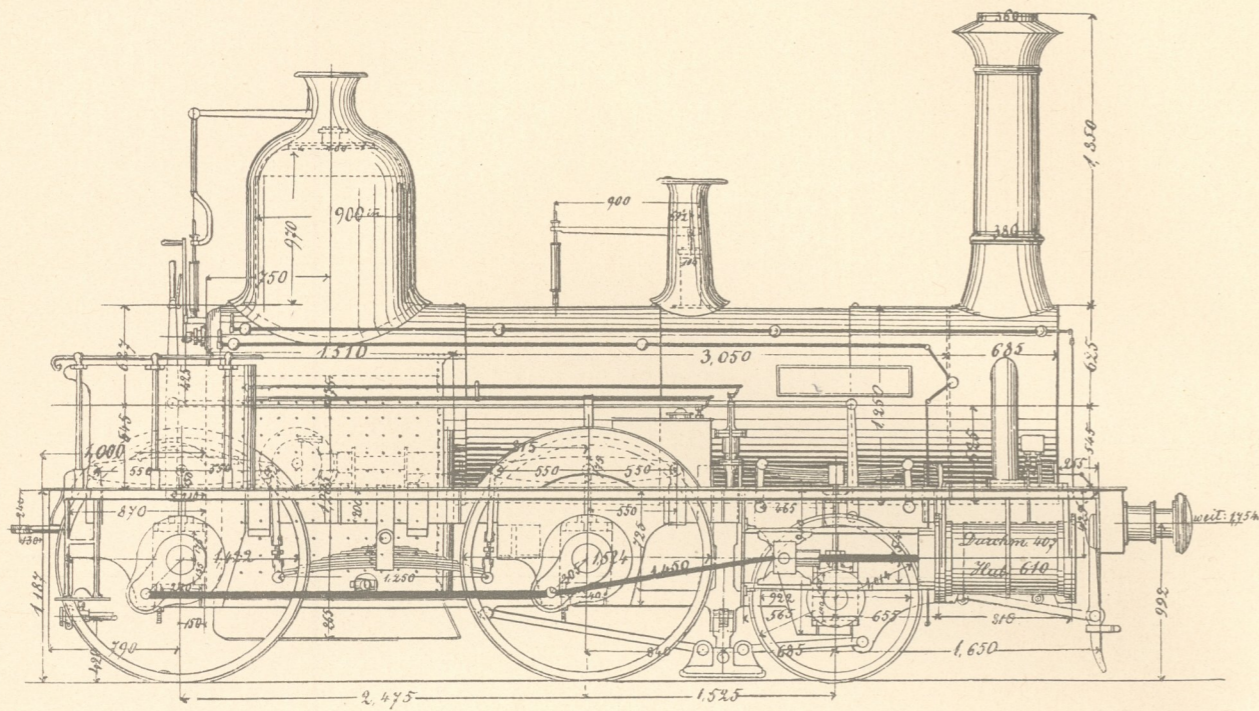

1 B, Sächs. Staatsbahn.

Erb. Hartmann 1854.

Steuerung nach Gonzenbach.

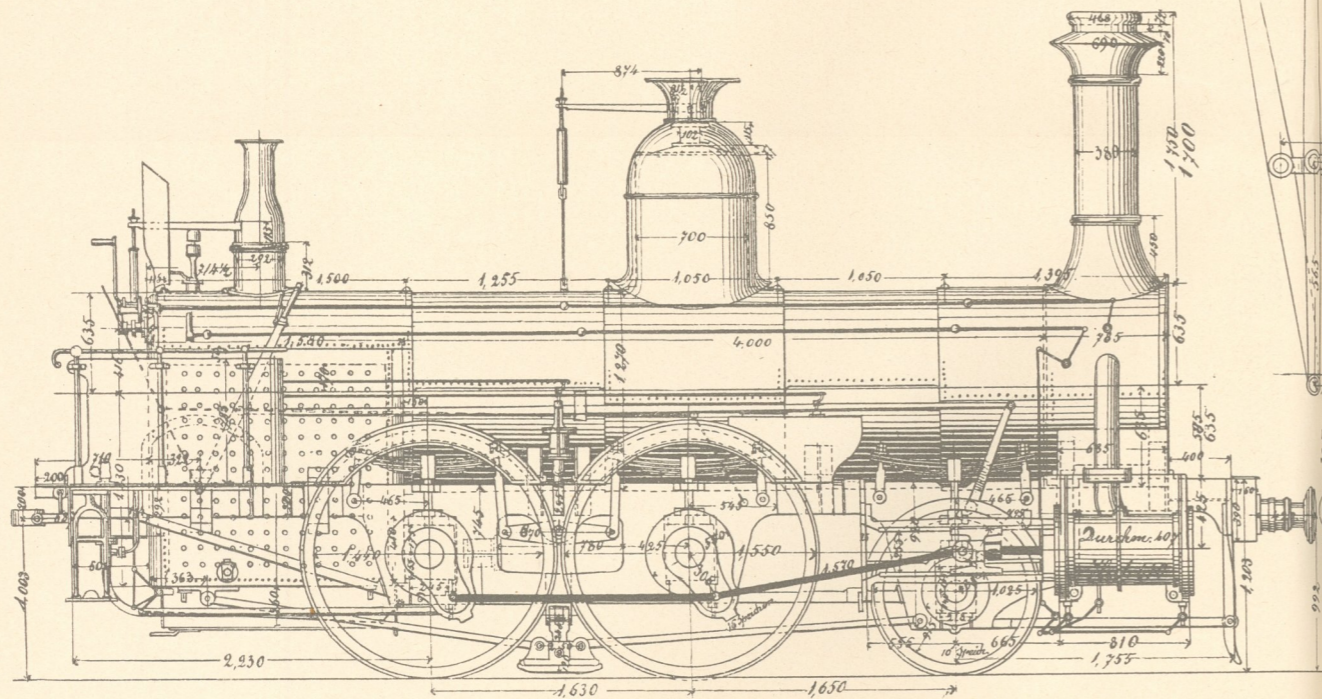

M. 1:47.

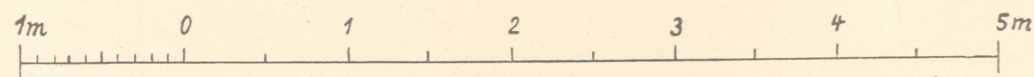

Dienstg. 26,5 t; Reibungsg. 20 t; Heizfl. 79,71 m²; Rostfl. 1,2 m²; p=7 atü;
d=407 mm; h=610 mm; D=1524 mm; Radst. 4000 mm; Leist. 264 PS_i (34 km/h).

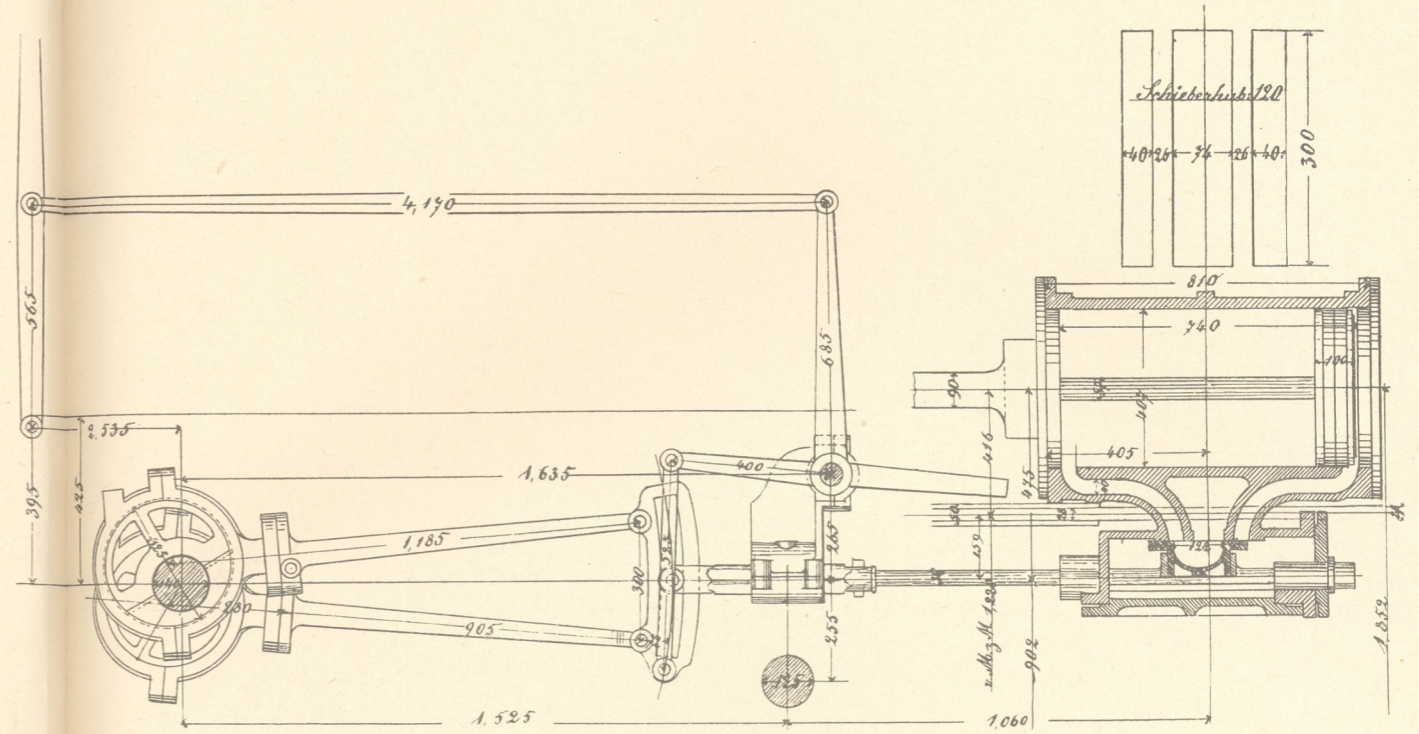

Dienstg. 29,1 t; Reibungsg. 21,6 t; Heizfl. 99,1 m²; Rostfl. 1,25 m²; p=7 atü;
d=407 mm; h=610 mm; D=1550 mm; Radst. 3280 mm; Leist. 296 PS_i (39 km/h).

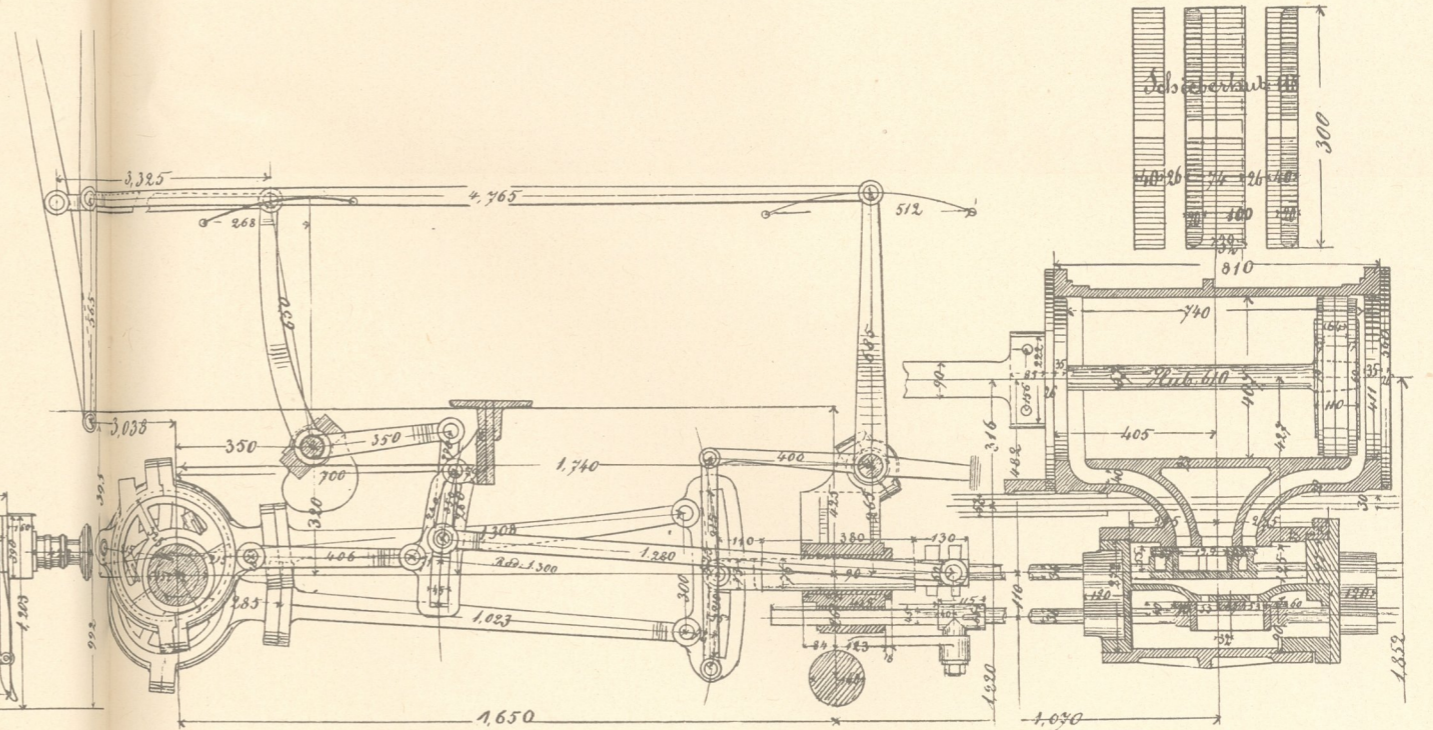

M. 1:19.

