

Lith. Anst. v. P. Wirtz, Darmstadt.

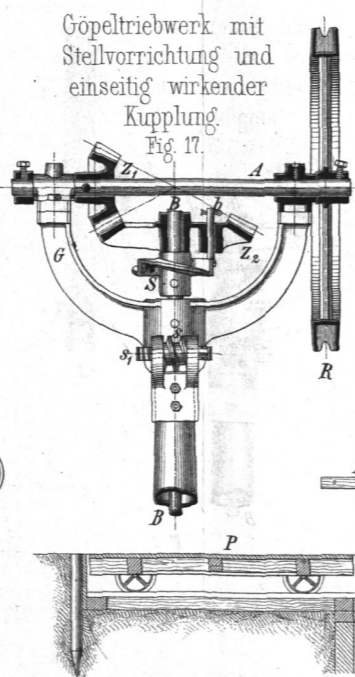

Vierpferdiger fahrbarer Säulengöpel von H. Lanz in Mannheim. M. 0,04.

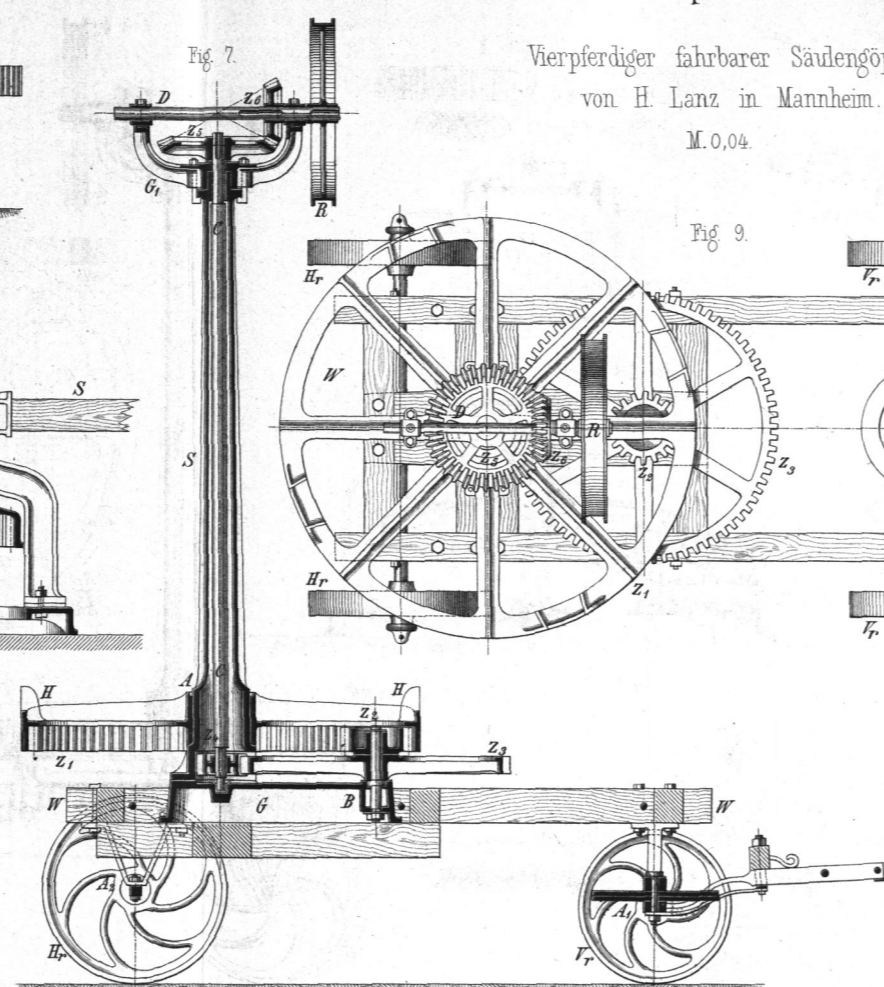
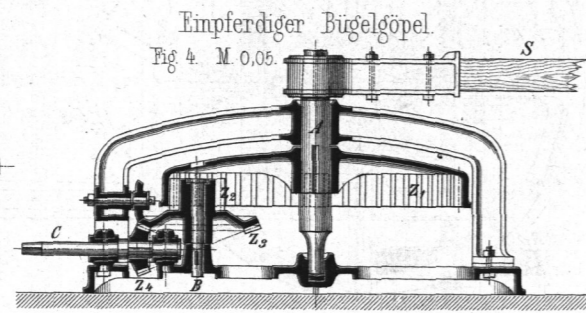
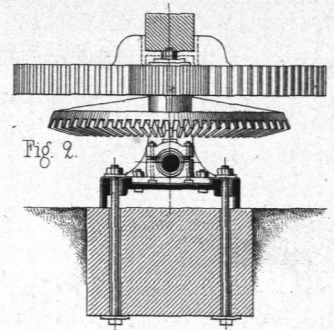
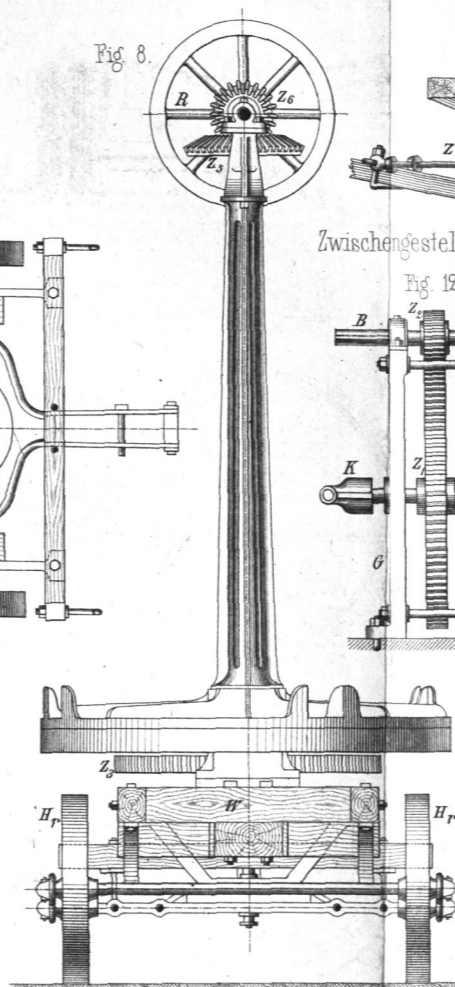

Pferdegöpel für Schachtförderung. Fig. 18. M. 0,009.

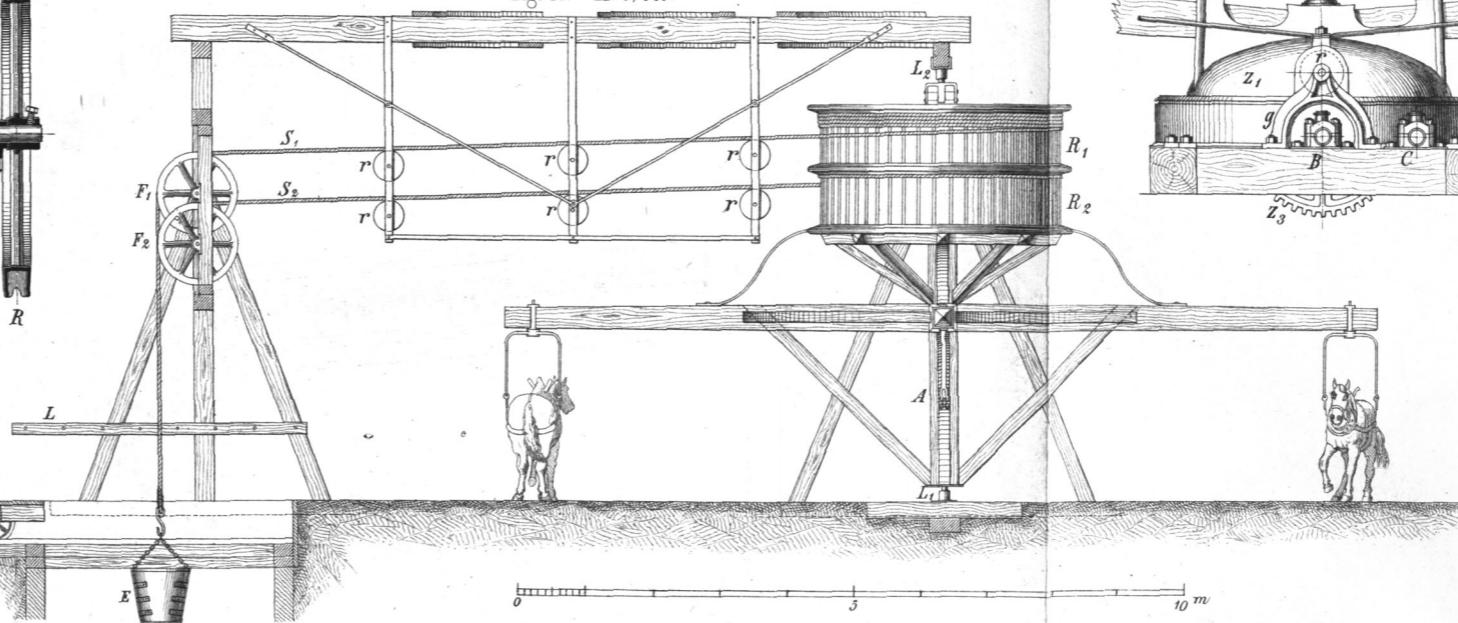

0 3 10 m

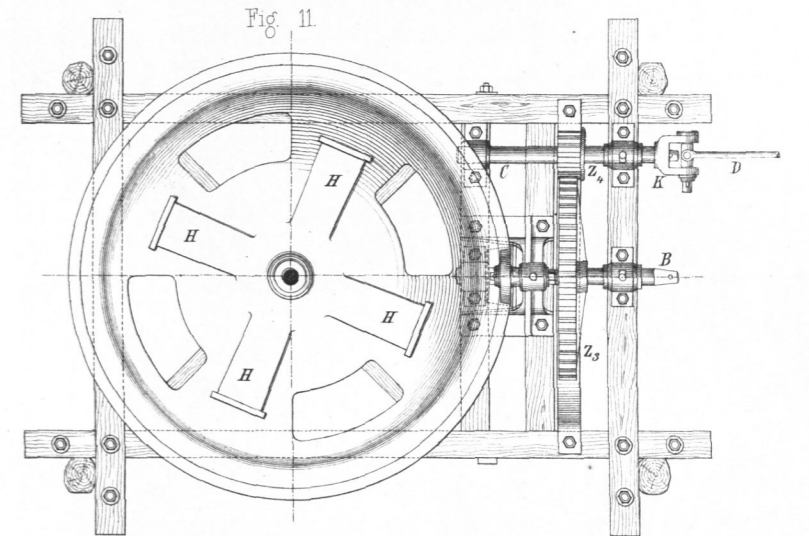
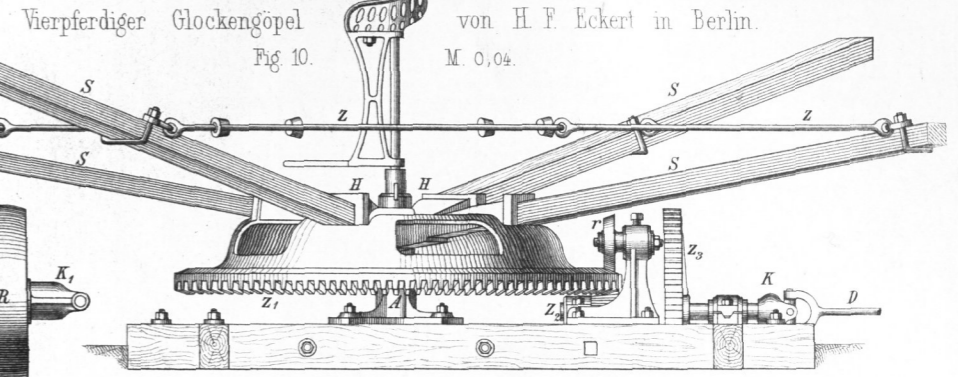
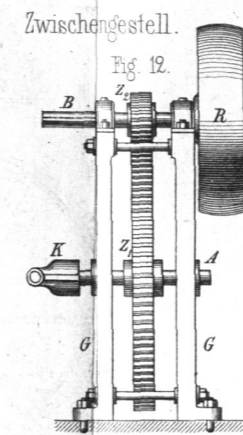

Bergner's zweipferdiger Glockengöpel.

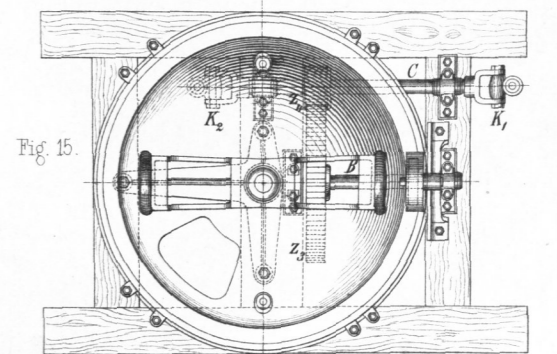
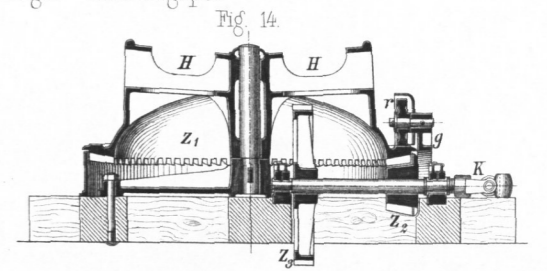
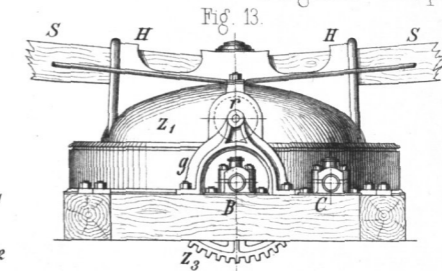

Verlag v. W. Engelmann, Leipzig.