

**Eincylinder-Express-Kompressor,**  
gebaut von A. Borsig in Berlin-Tegel.

Abb. 31. Seitenansicht des Kompressors. Masst. 1:15.



Abb. 32. Grundriss des Kompressors. Masst. 1:15.



Abb. 33. Längsschnitt des Kompressors. Masst. 1:15.

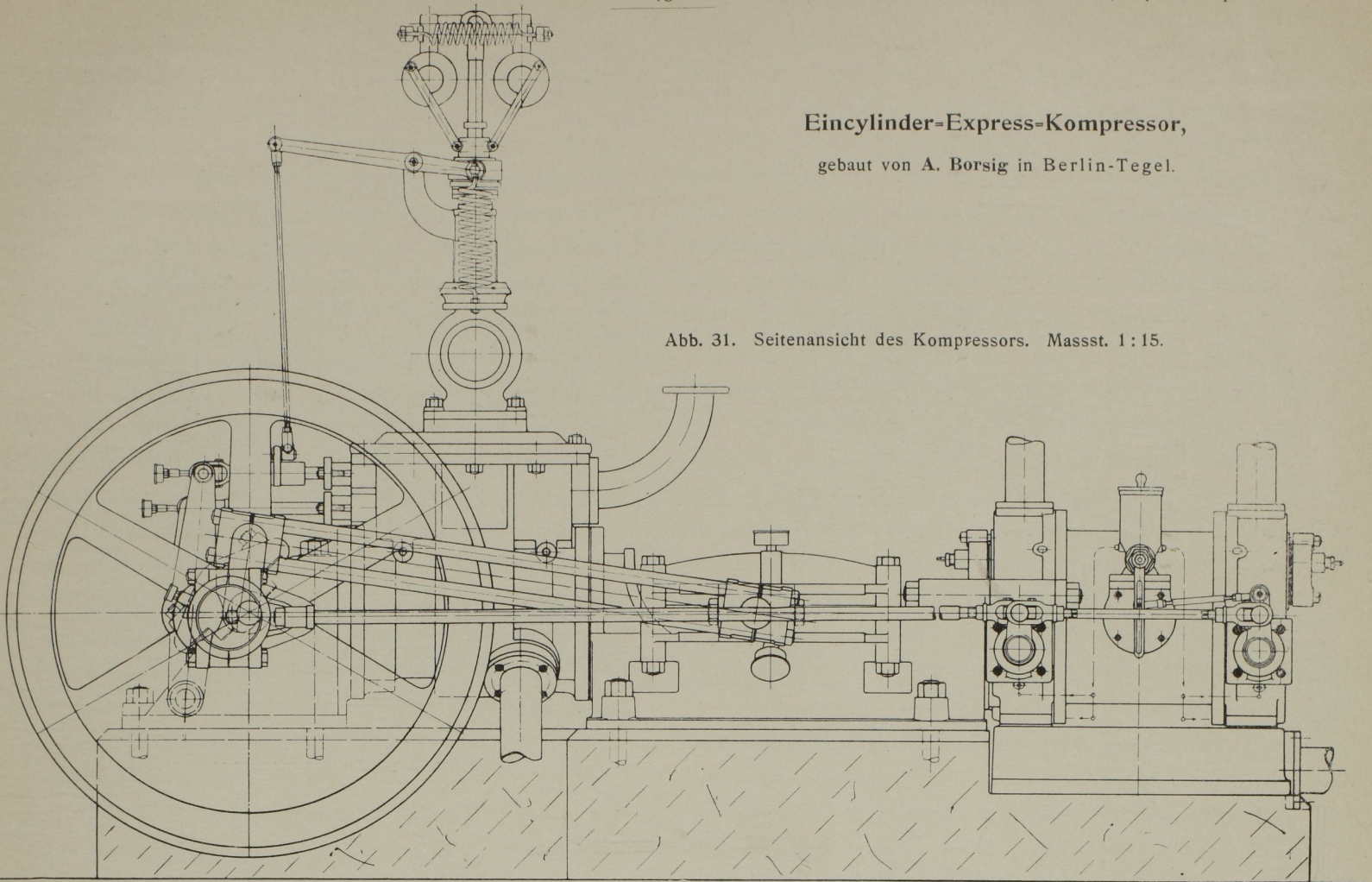
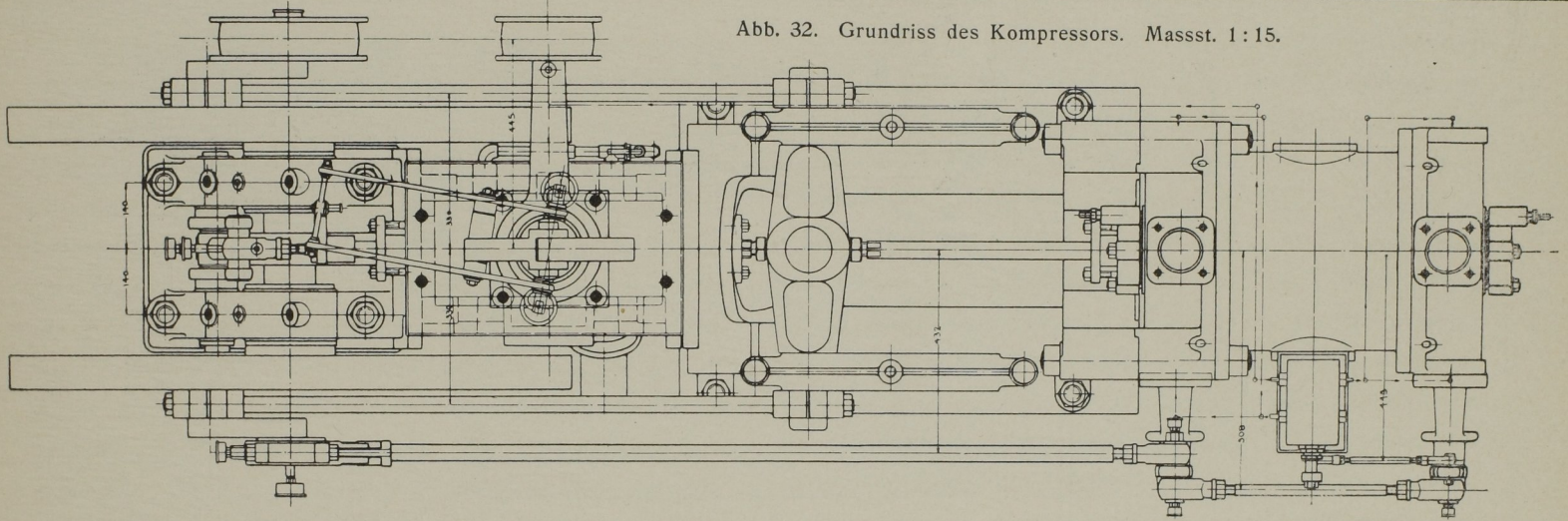