

Dernier montant

Montant intermédiaire

Montant du milieu

Fig.1 - Elevation

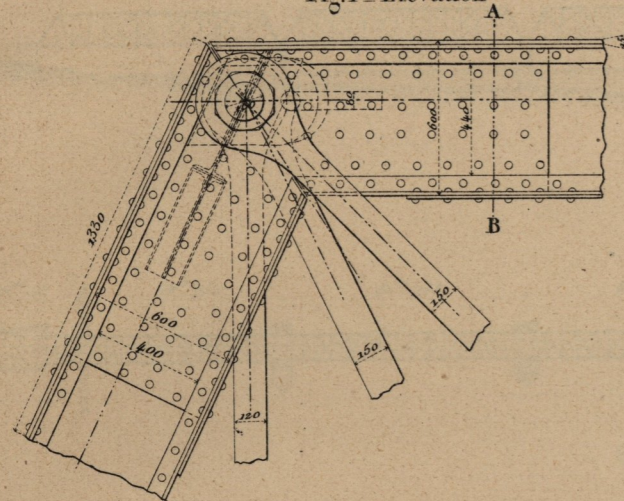

Fig.2. Coupe AB.

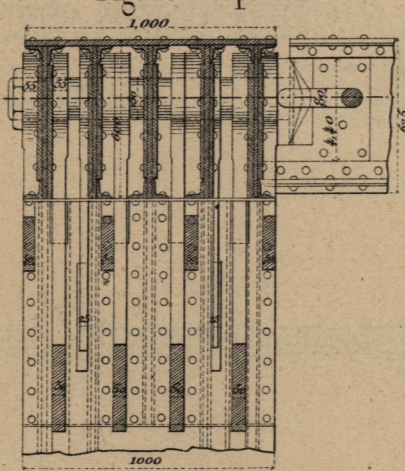

Fig.3 - Elevation c

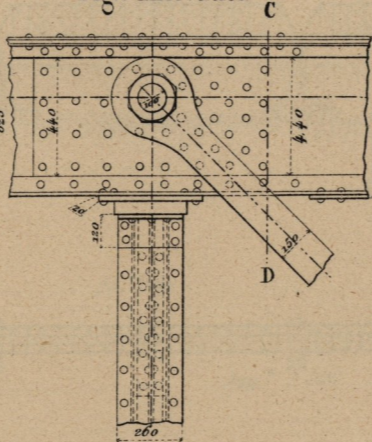

Fig.4 - Coupe CD

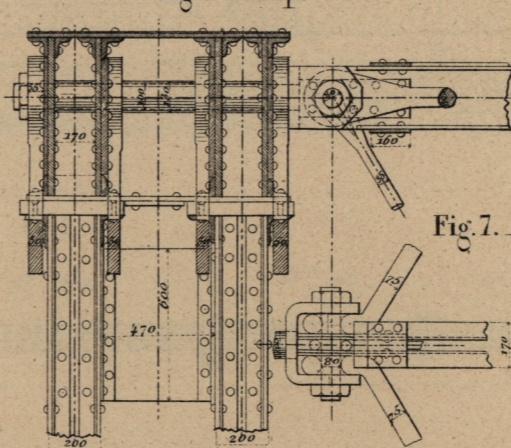

Fig.10. Elevation

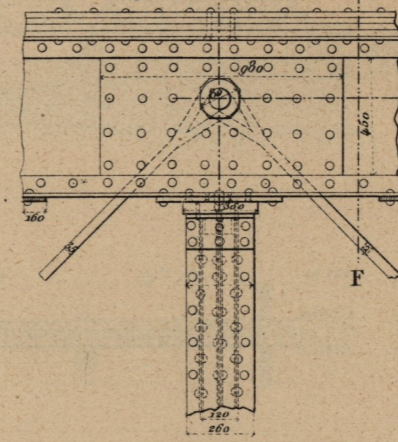

Fig.11. Coupe EF

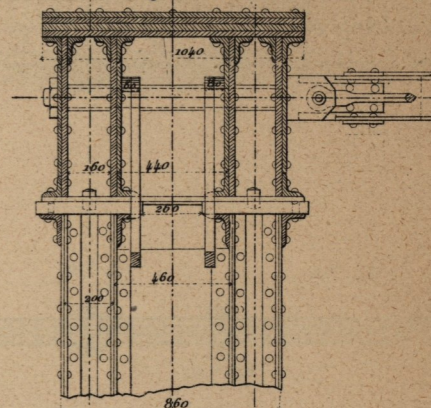

Fig. 12

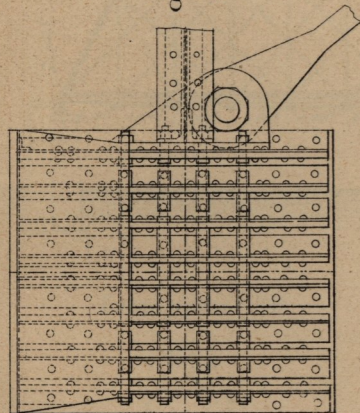

Fig.15 - Coupe GH

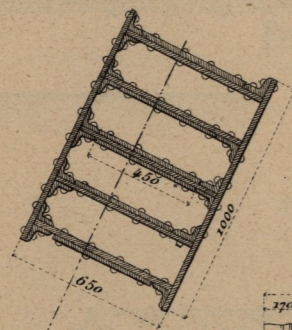

Fig. 5

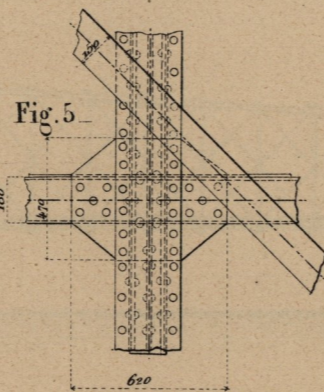

Fig.6

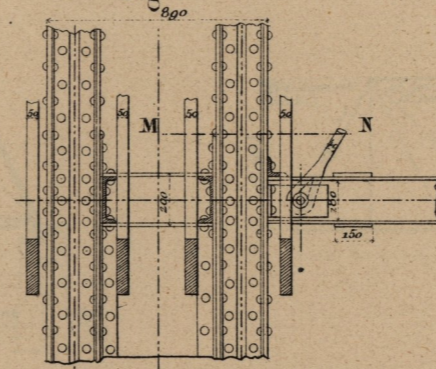

Fig.9 - Coupe MN

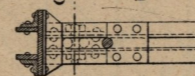

Fig. 19

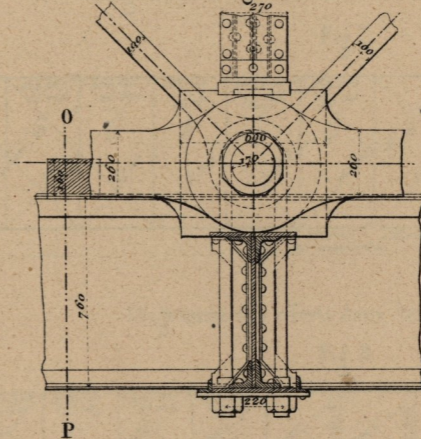

Fig. 20

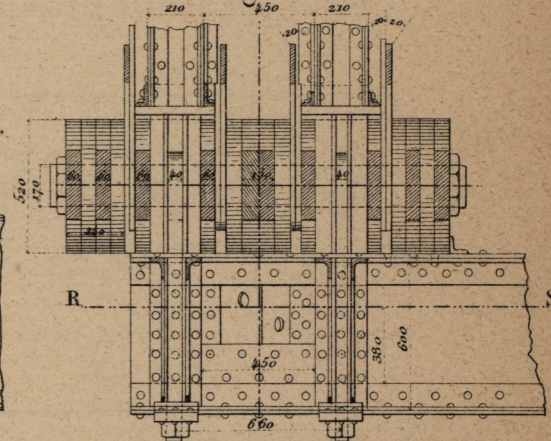

Fig. 21. Coupe RS

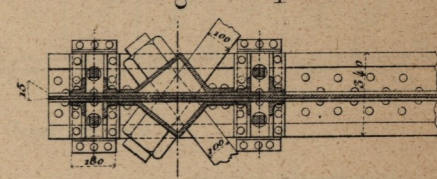

Fig.13

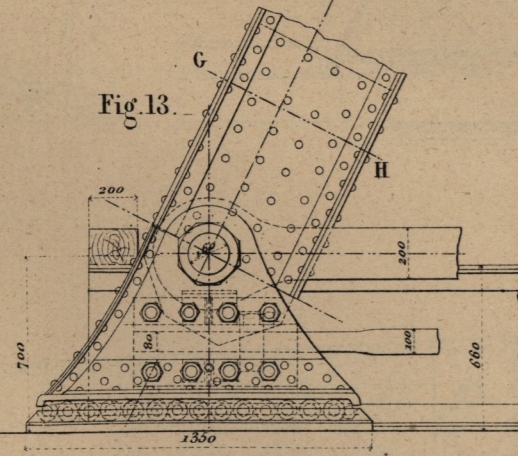

Fig.14

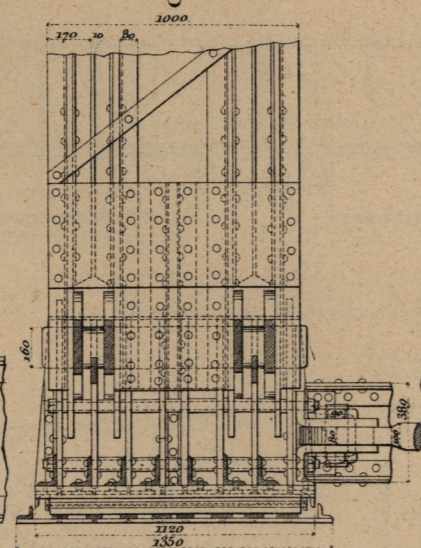

Fig.16

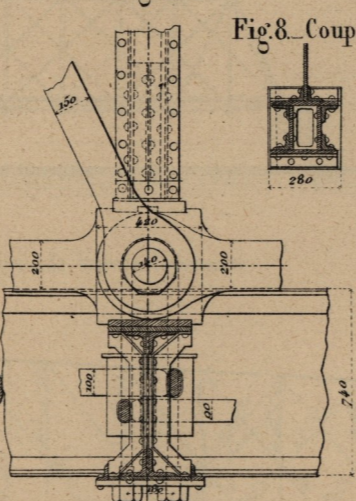

Fig.8. Coupe KL

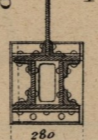

Fig.17

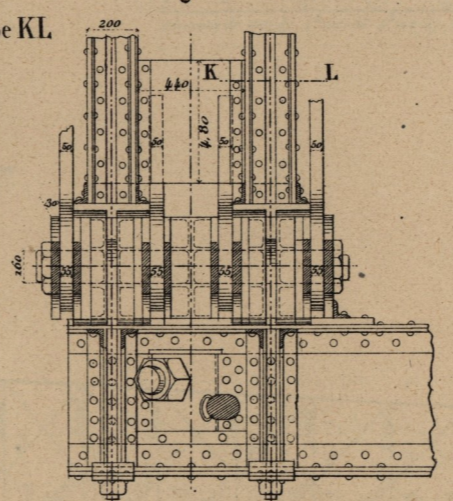
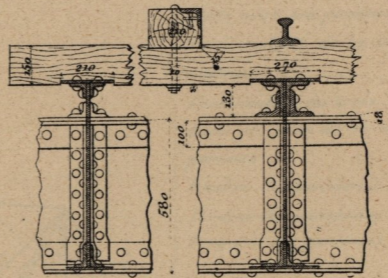

Fig.18 - Coupe OP



Echelle des détails: 30