

Innerer Ausbau.

Abtheilung II * Serie I

Die Arbeiten des Bautischlers.

Fussboden-Konstruktionen, Thore für Ställe, Scheunen und Remisen; Zimmer- und
Hausthüren, Schiebethüren, Thüren für Kirchen und Schulen, Windfänge, Beschläge u. s. w.

Eine Sammlung der gebräuchlichsten Konstruktionen
mit Einzelheiten im Stile der Gothik und Renaissance.

Zum Gebrauch für Ausführende und Studierende des Baufachs

zusammengestellt von

MARTIN MEYER

KÖNIGLICHER BAUSCHUL-OBERLEHRER UND PROFESSOR.

Tafel 1—30.



Deutsch-Krone

Verlag von F. ZIEBARTH'S Buchhandlung (Inhaber: A. Schapler)
1900.



4337
4

Innerer Ausbau.

Abtheilung II * Serie I

Die Arbeiten des Bautischlers.

Fussboden-Konstruktionen, Thore für Ställe, Scheunen und Remisen; Zimmer- und Hausthüren, Schiebethüren, Thüren für Kirchen und Schulen, Windfänge, Beschläge u. s. w.

Eine Sammlung der gebräuchlichsten Konstruktionen
mit Einzelheiten im Stile der Gothik und Renaissance.

Zum Gebrauch für Ausführende und Studierende des Baufachs

zusammengestellt von

MARTIN MEYER

KÖNIGLICHER BAUSCHUL-OBERLEHRER UND PROFESSOR.

Tafel 1—30.



Deutsch-Krone

Verlag von F. ZIEBARTH'S Buchhandlung (Inhaber: A. Schapler)

1900.

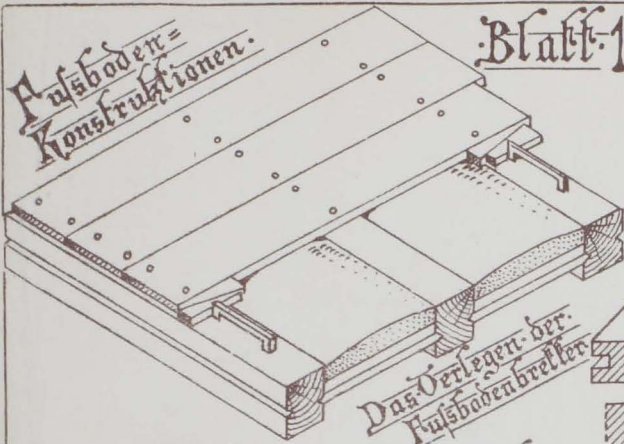

Das Verlegen der Fußbodenbretter

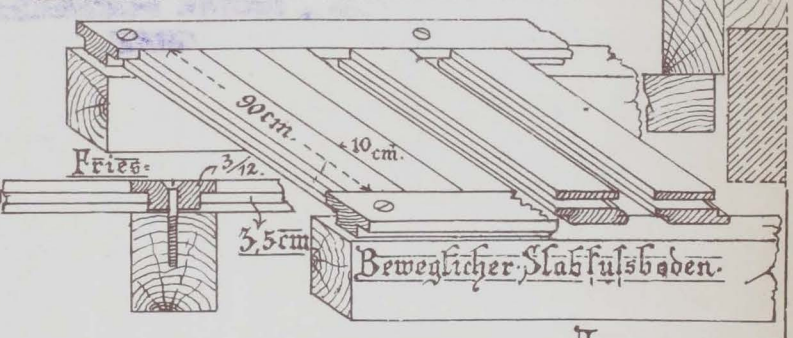
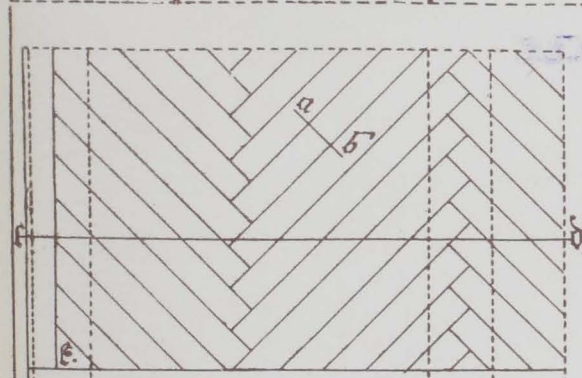
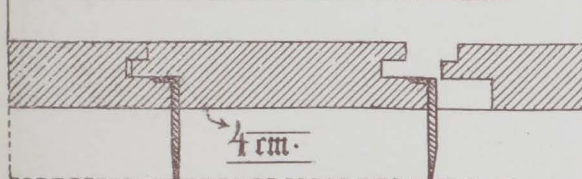
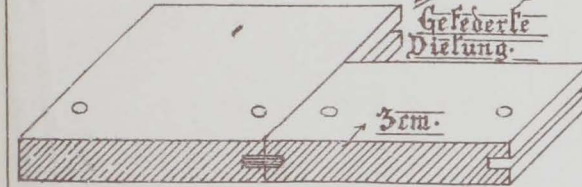
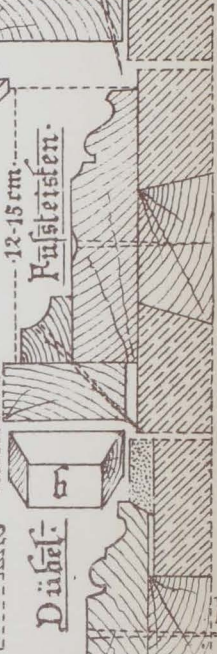
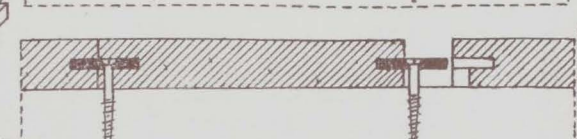
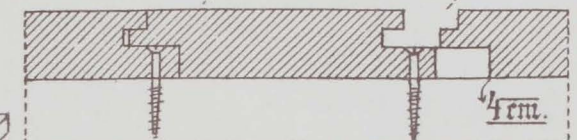
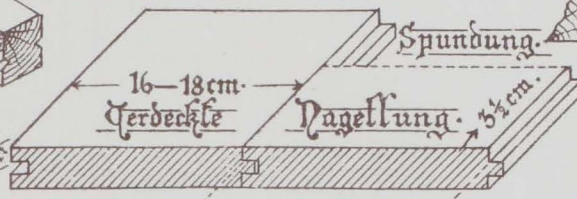
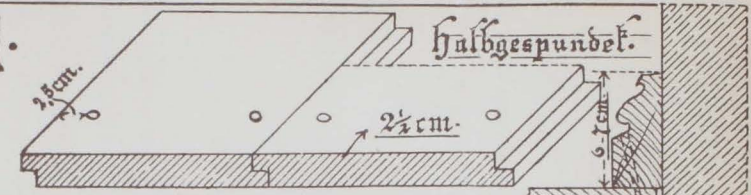

Slabfußboden auf Blindboden.

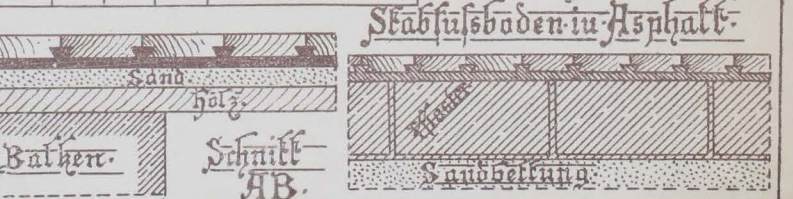
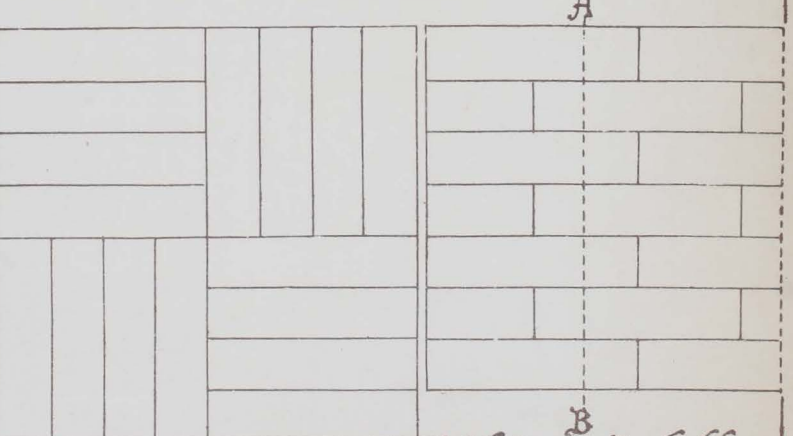
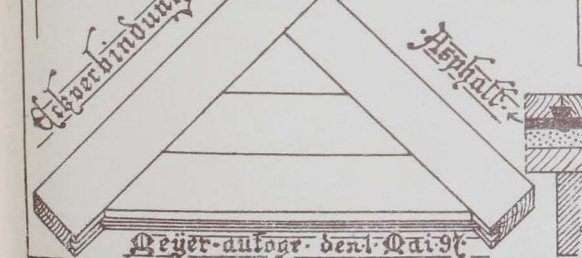

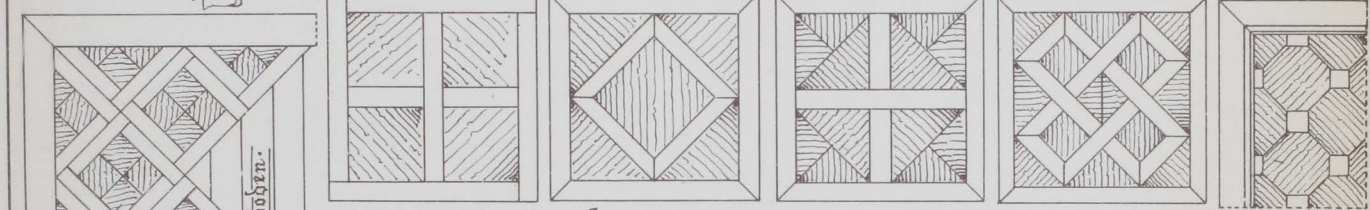
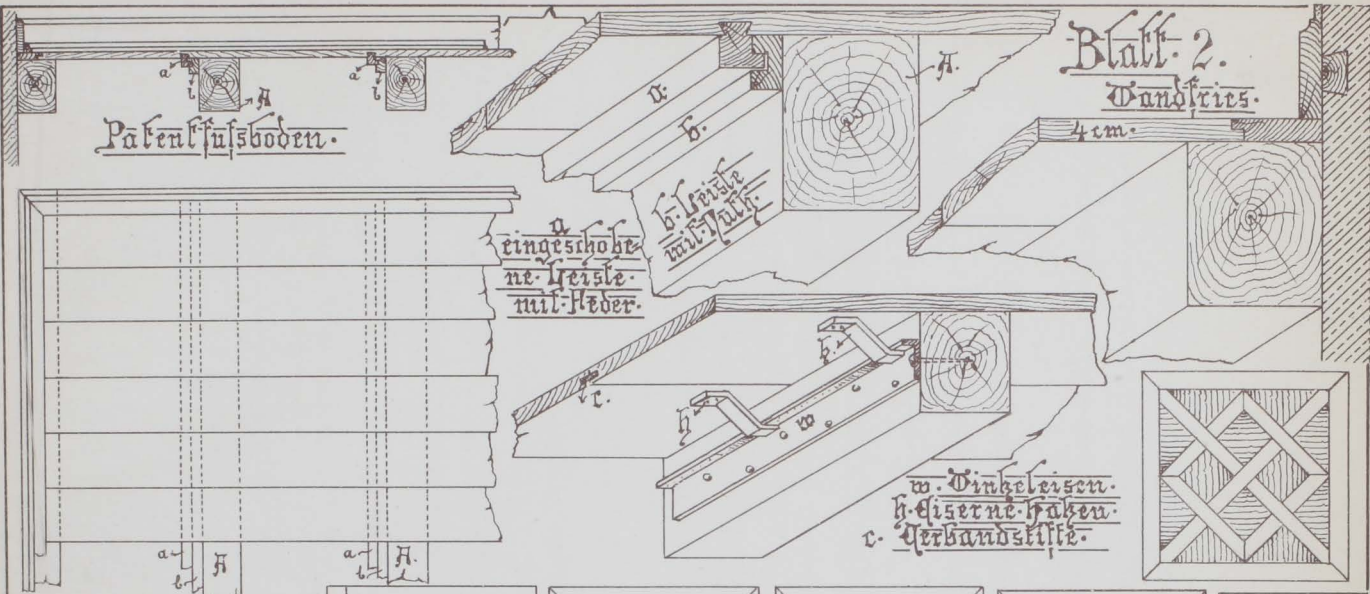

Parquetierte Fußböden. Größe der Tafeln: 35-50 cm. Seitenlänge

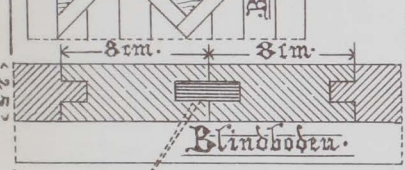

Beweglicher Fußboden nach Helzer.

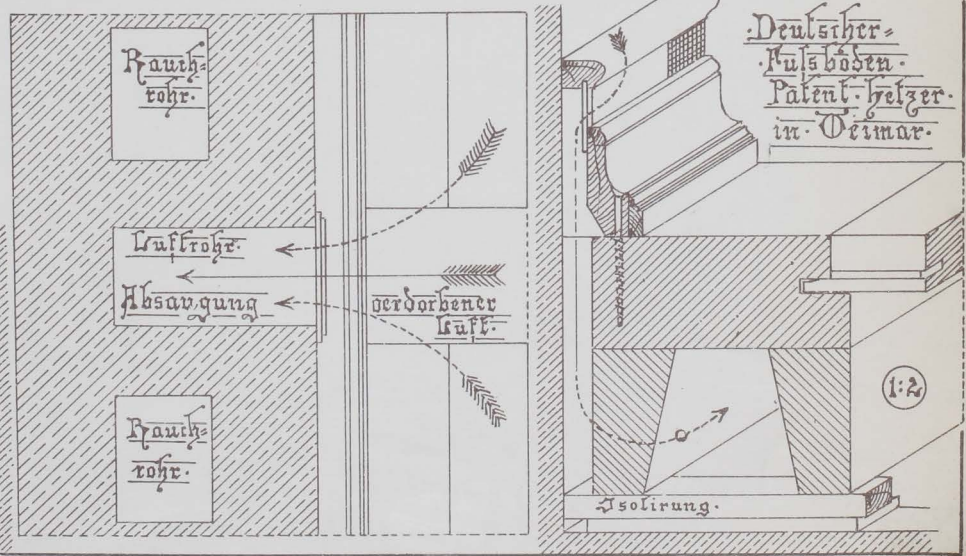
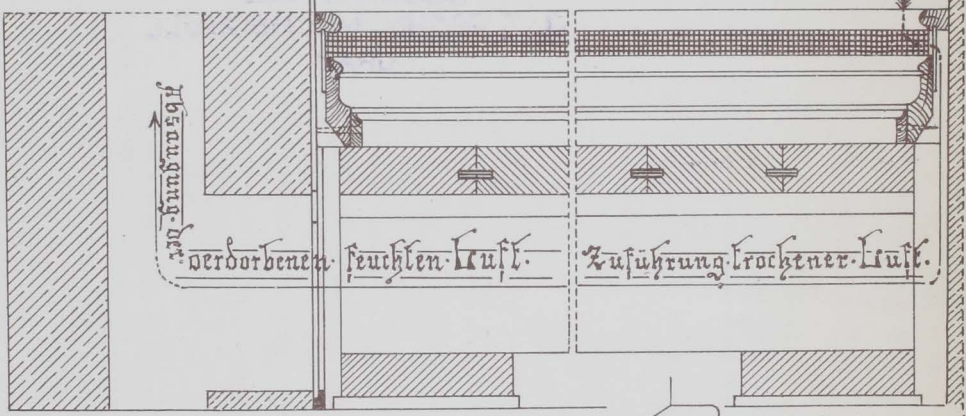
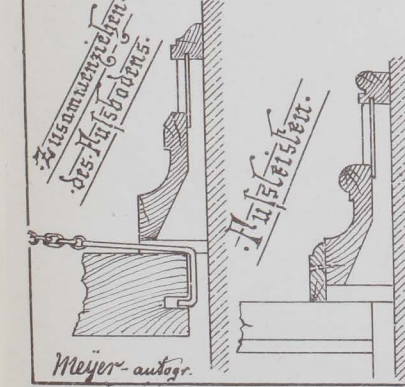
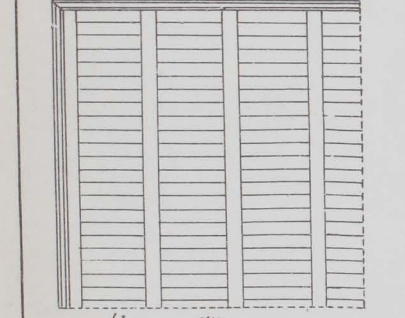

Jalousie-
Thüren.

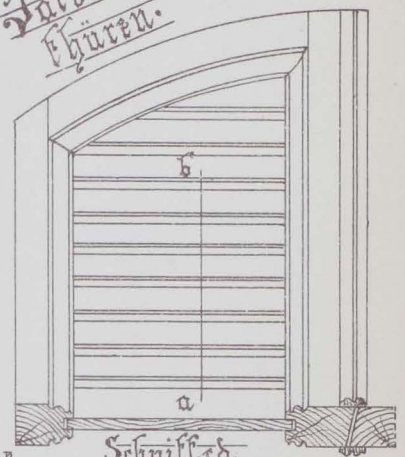
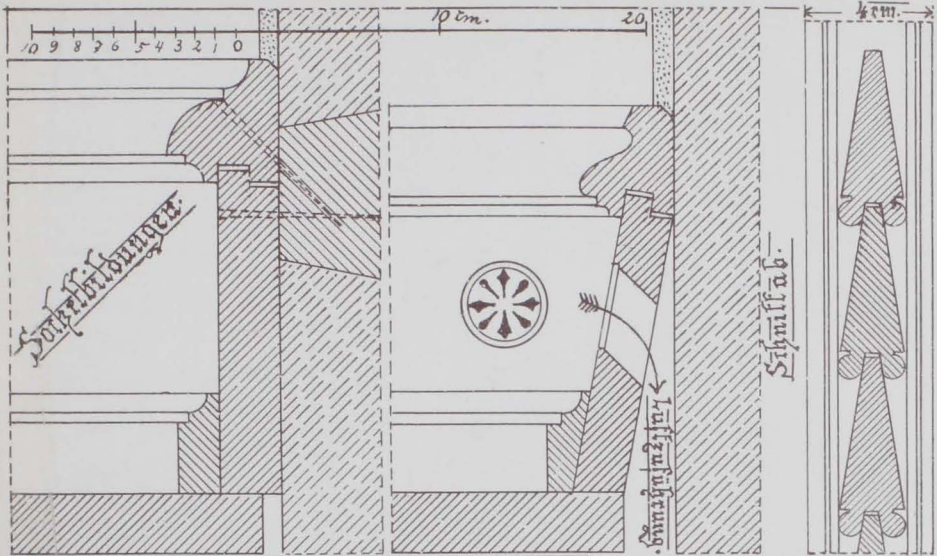

Schnitt ed.

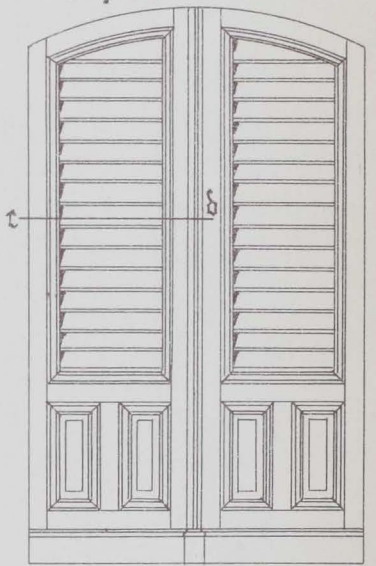
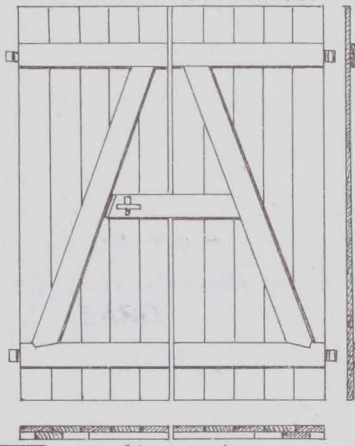
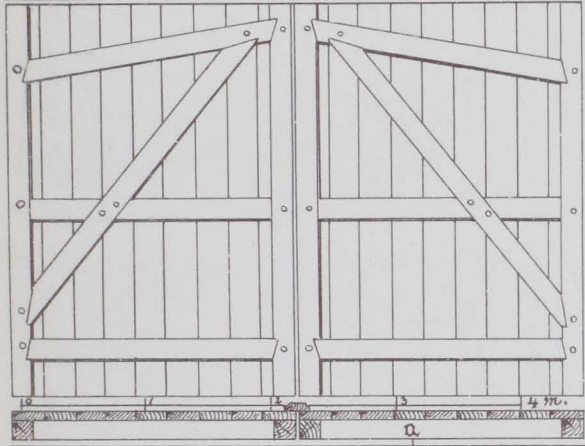

Stall- und Scheunen-
Thüren.

14 Bildung der
Sockel- und Zwischenrahmen.

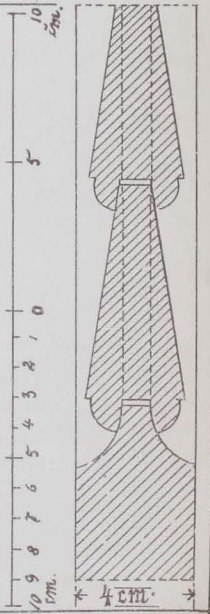
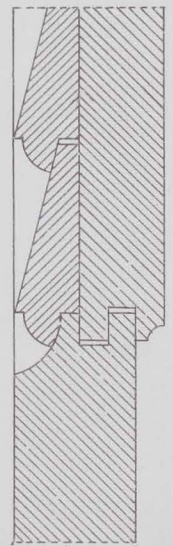
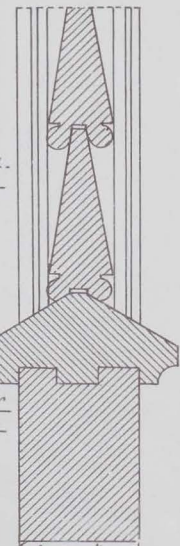
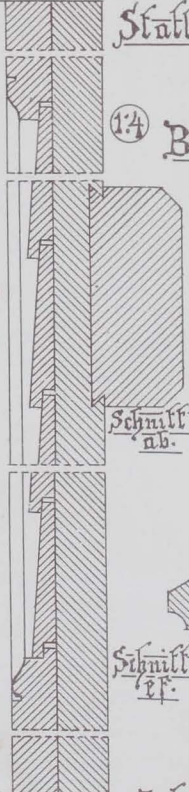
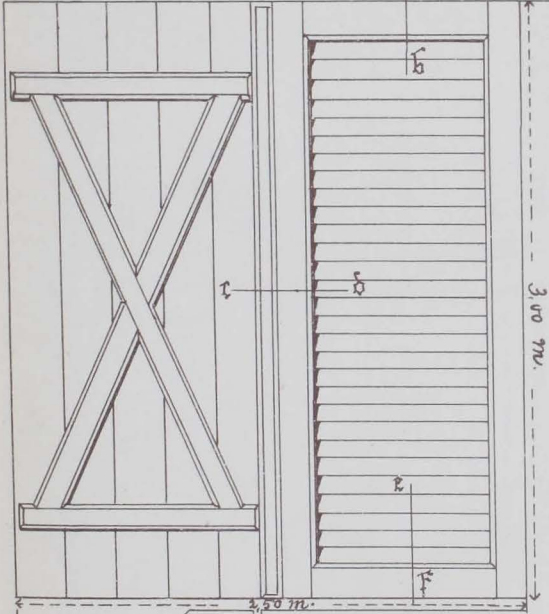

Schnitt ed. 14

Gespundete Bretterthüren mit aufgenagelten Jalousien.

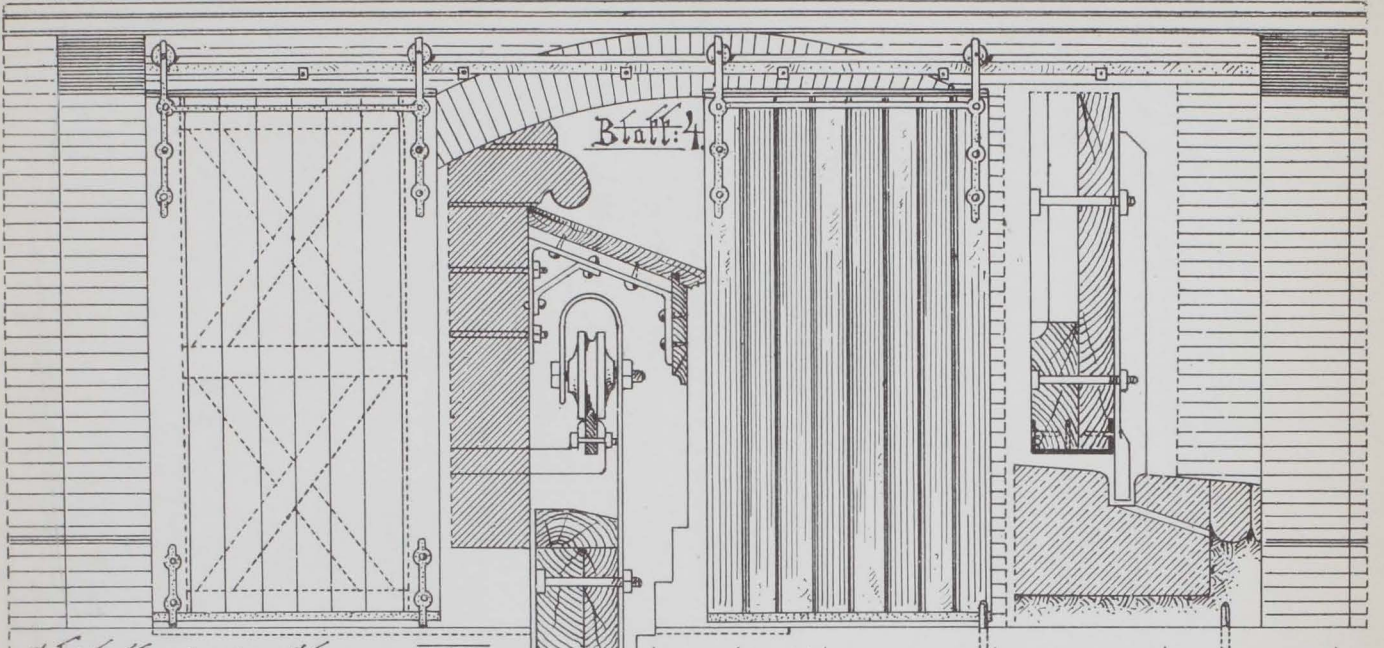

Schiebelhor. für eine Scheune. 1:40.

100 mm. 50 40 30 20 10 0

Details. 1:10.

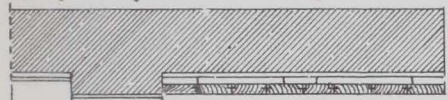

Schiebelhor
für
Hochwerhscheu-
nen.

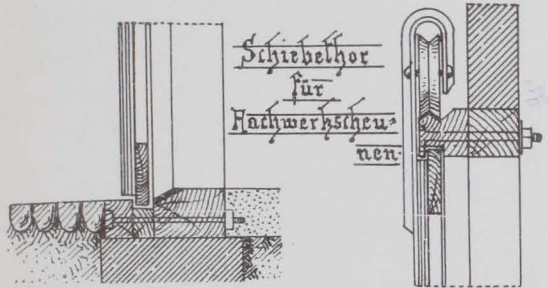

Beschläge 1:4.

für eine Remise.

16.

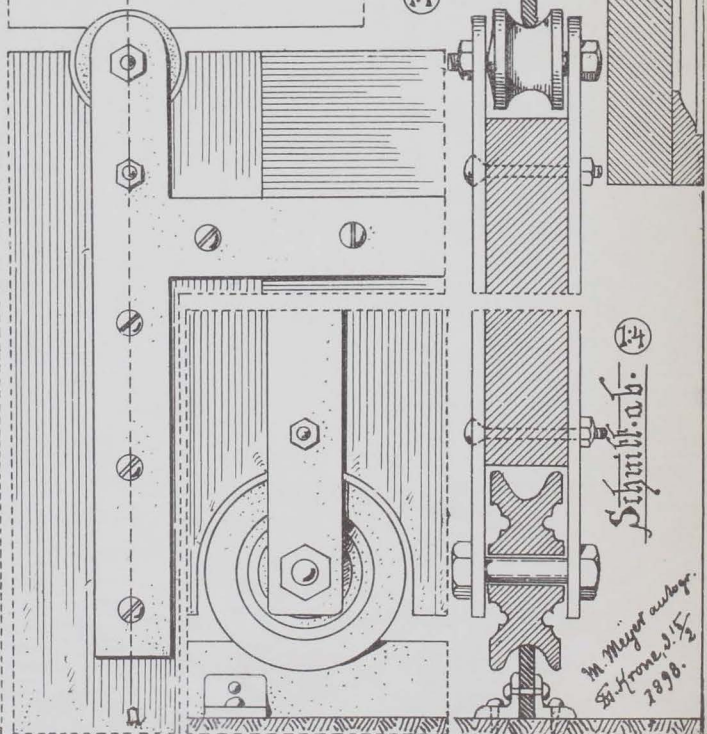
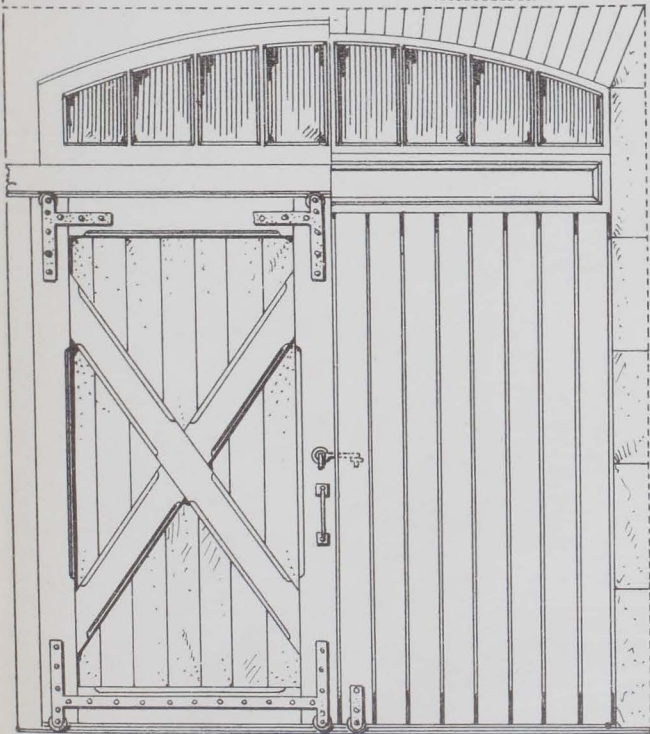
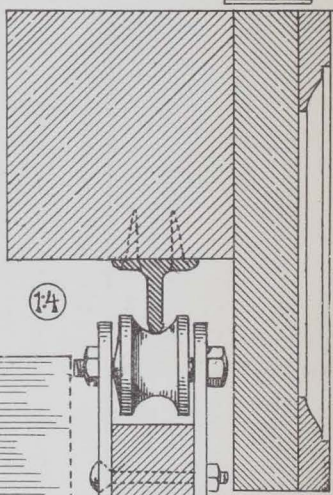

Schnitt a-b.

M. Meyer a.d. H.
St. Home. J. 1/2
1898.

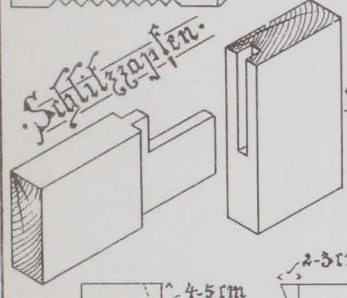
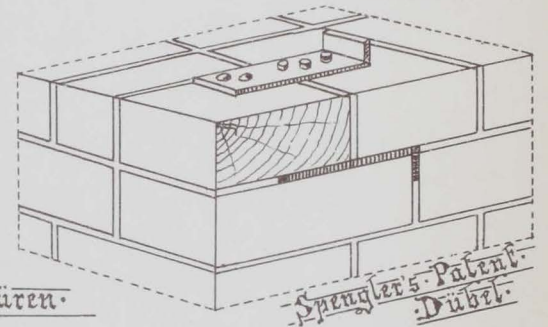
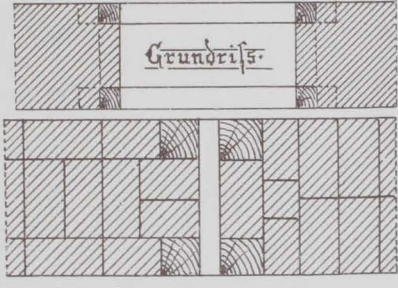
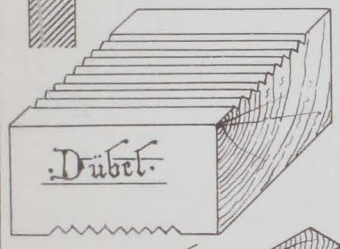
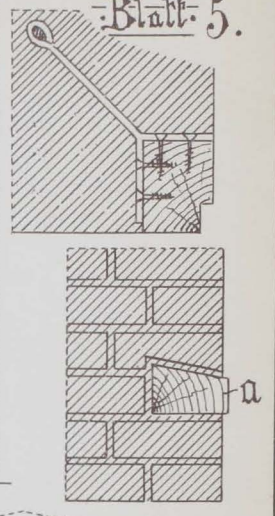
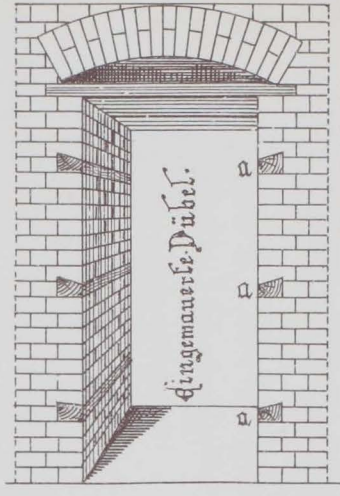
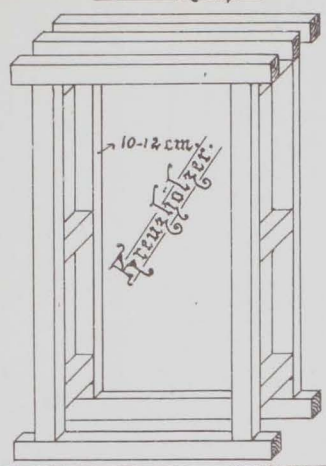
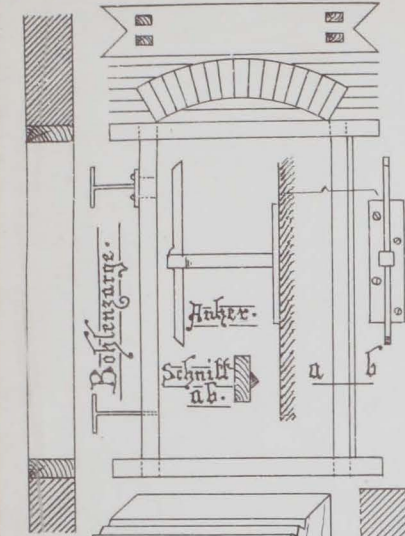

Gestemmte einflügelige Zimmerthüren.

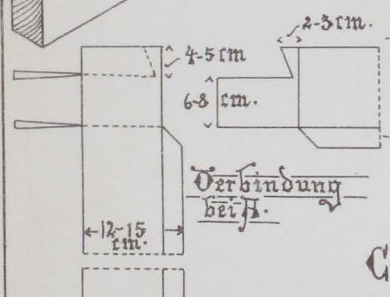

Verbindung bei A.

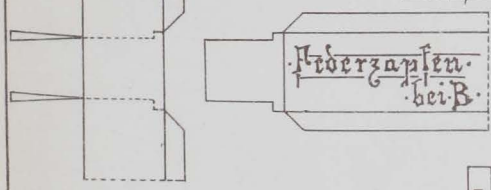
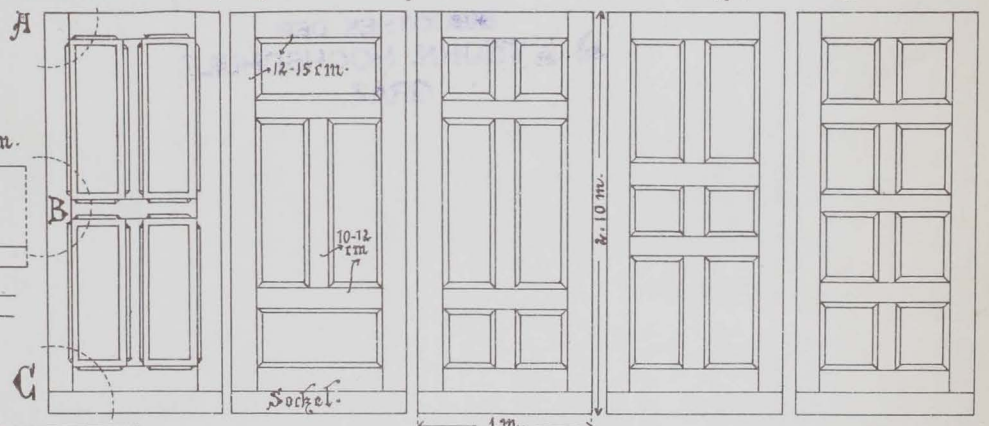

Verbindung der Rahmenhölzer.

Zinken der.

Türfüller.

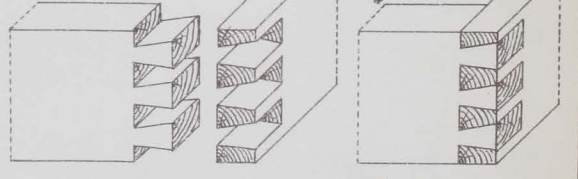

Verbindung bei C.

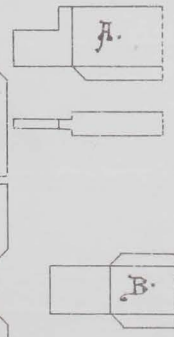
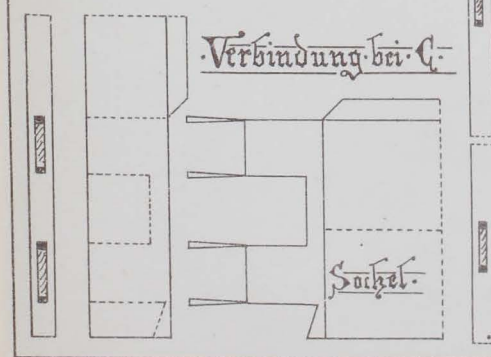

Verdeckt-gezinkt.

Zinzung auf-Gehrung.

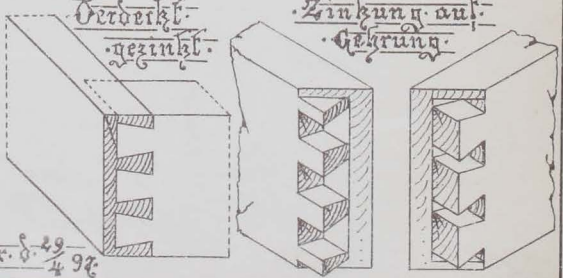

Einflügelige Zimmerthür Ansicht.

Schnitt

Blatt 6.

Querschnitt

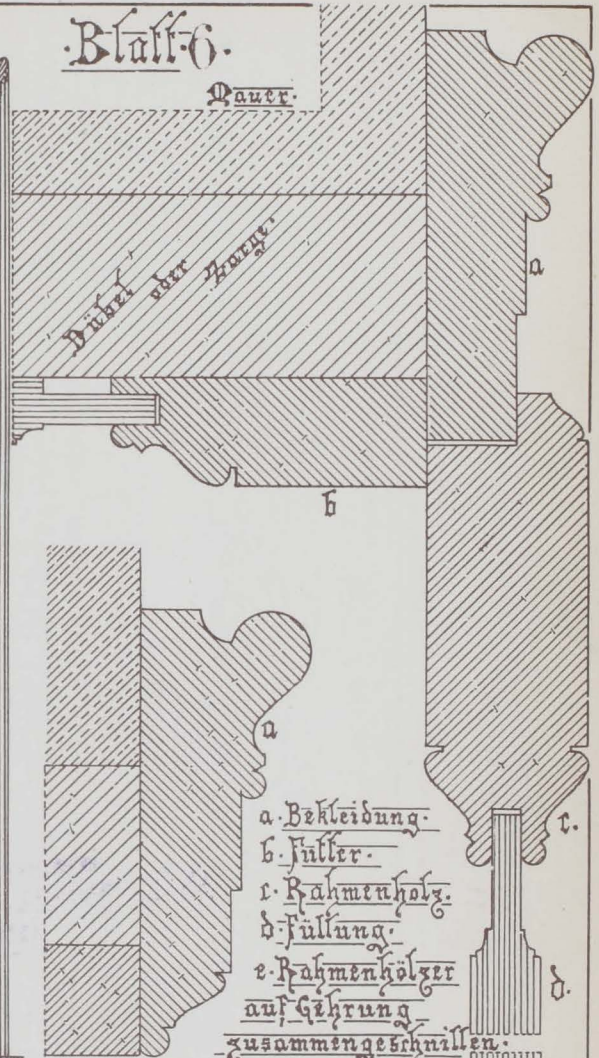
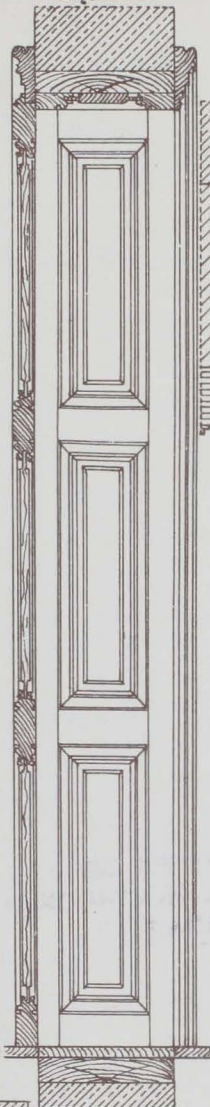
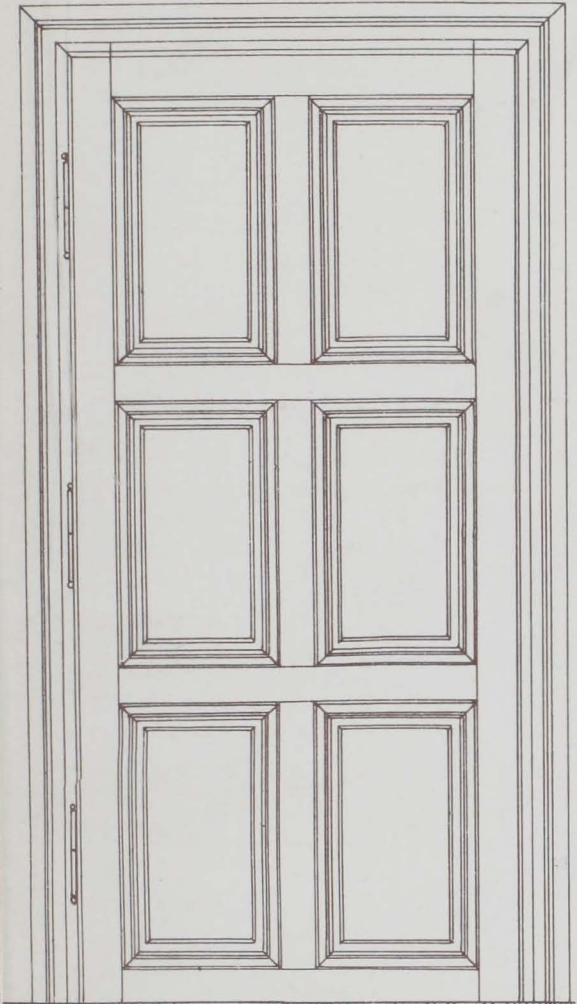

- a. Bekleidung.
- b. Füller.
- c. Rahmholz.
- d. Füllung.
- e. Rahmenholz auf Führung zusammengeschnitten.

g. Feder aus Holz oder Zink.

Grundriß 1:15.

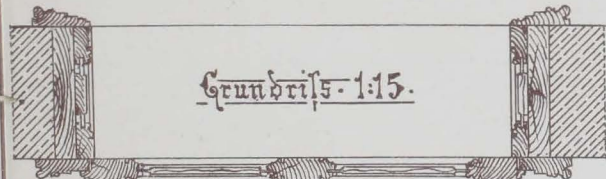

Details in 1/2 natürlicher Größe.

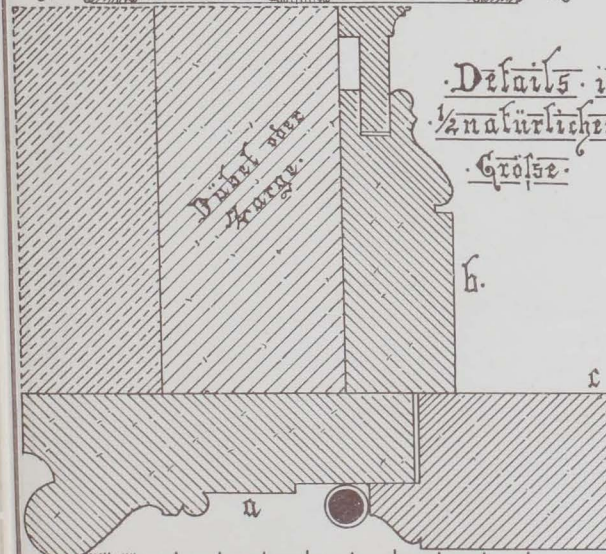
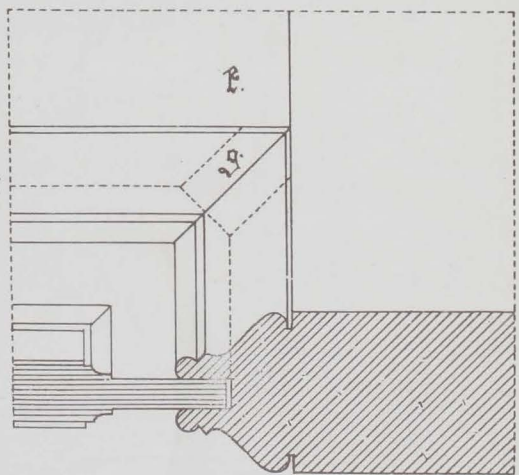

0 10 20 30 40 50 60 70 80 90 100 cm.

2 Meter.

Meier'sche
Zurich 96.



Blatt 7.

1,5 m.

100 cm.

90

80

70

60

50

40

30

20

10

0

10 5 0

Einflügelige Zimmerthür Kirk u. Seibert entw.
Aus: Der praktische Bauischler.

Deyer aulogr. d. 2/8
96.

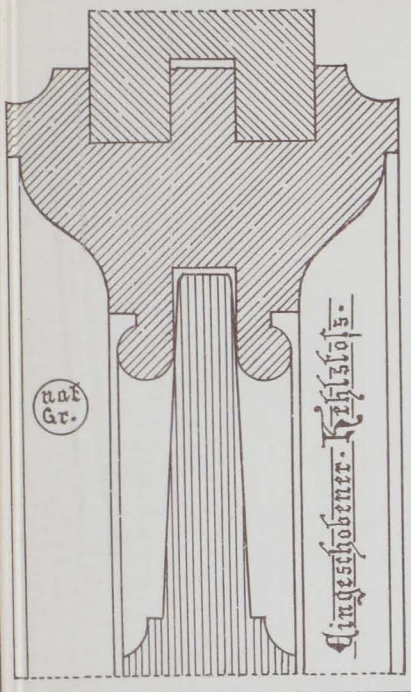

Eingestobener Kehlsloß.

2:1

Gestimmtes Pulver mit eingelassenen Kehlsloß

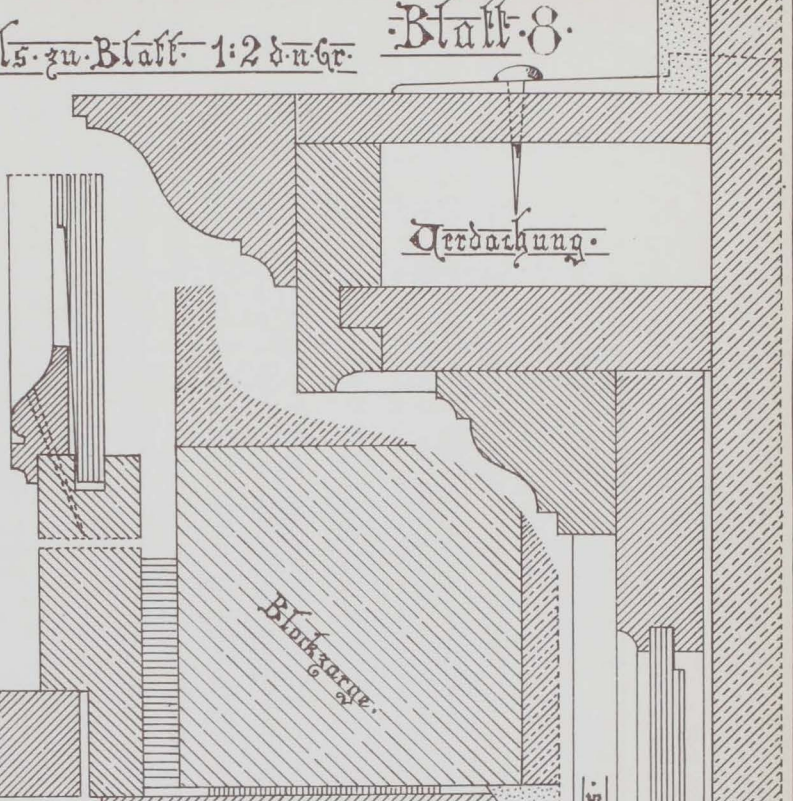

Verdachung.

Blankzarge.

Fries.



Einfache Kehlung.

1:1

Ganz im Holz liegende Tür.



Blankzarge.

Gestimmtes Pulver.

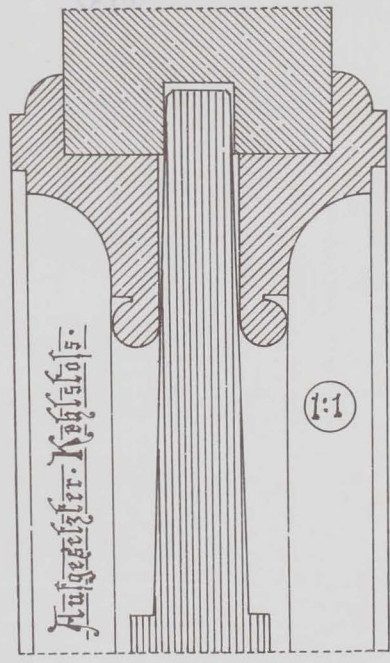

Aufgesetzter Kehlsloß.

1:1

Bekleidung.

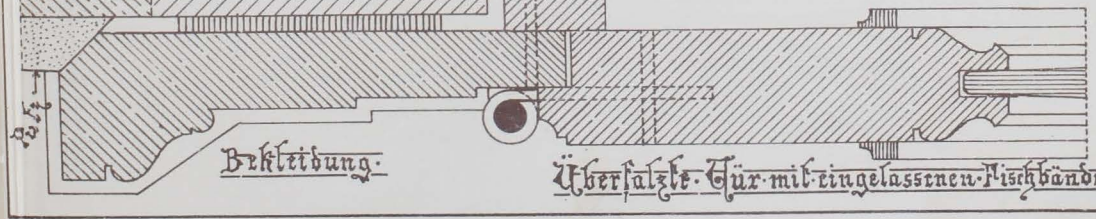

Bekleidung.

Überfalzte Tür mit eingelassenen Nischbänder

2.5.79.96. Meyer

Blatt 9.

Zweiflügelige innere
Pällungsthür.

Schnitt AB. 1:2 nat. Gr.

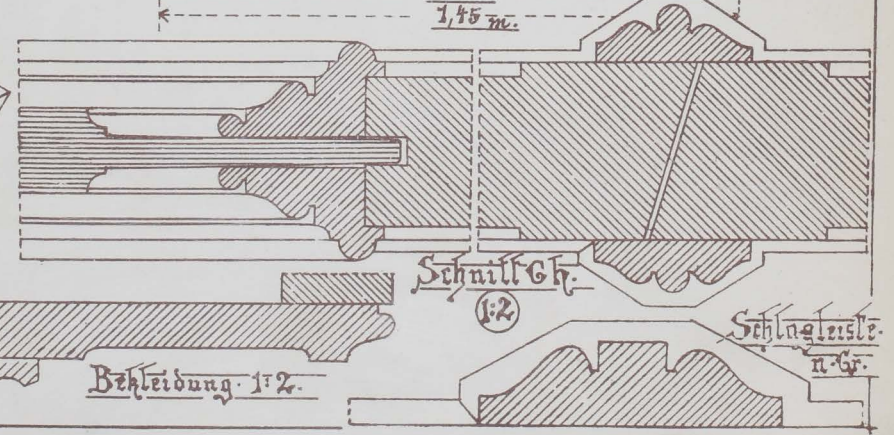
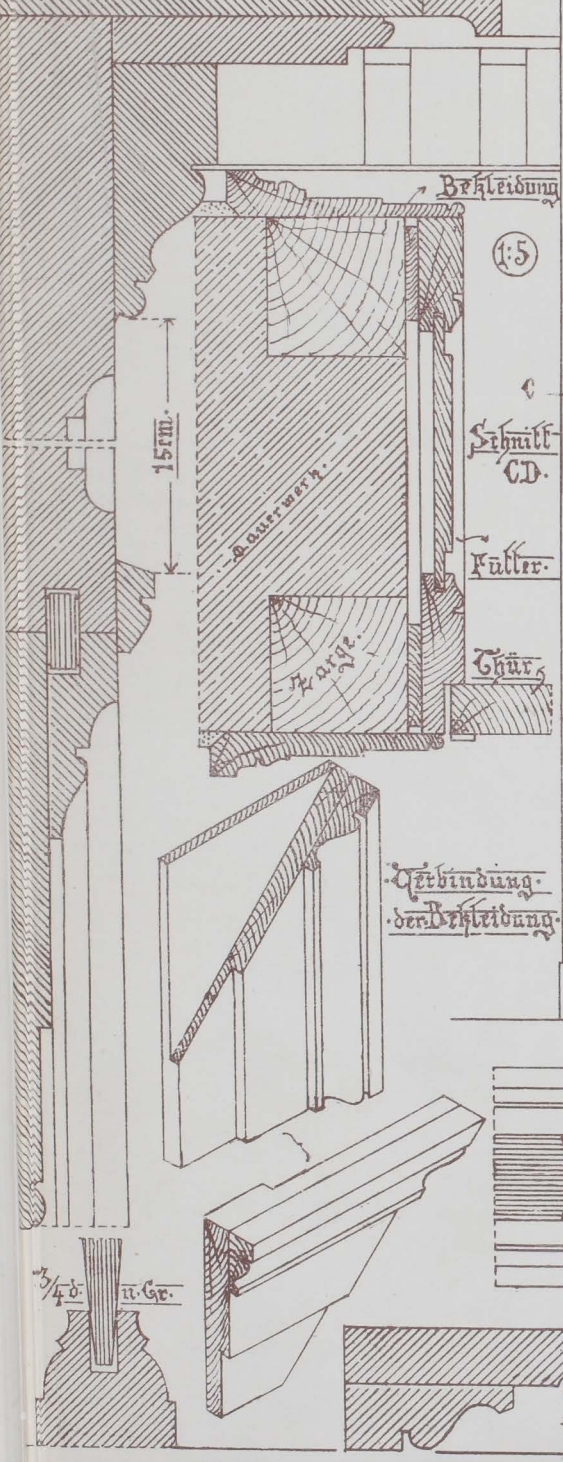
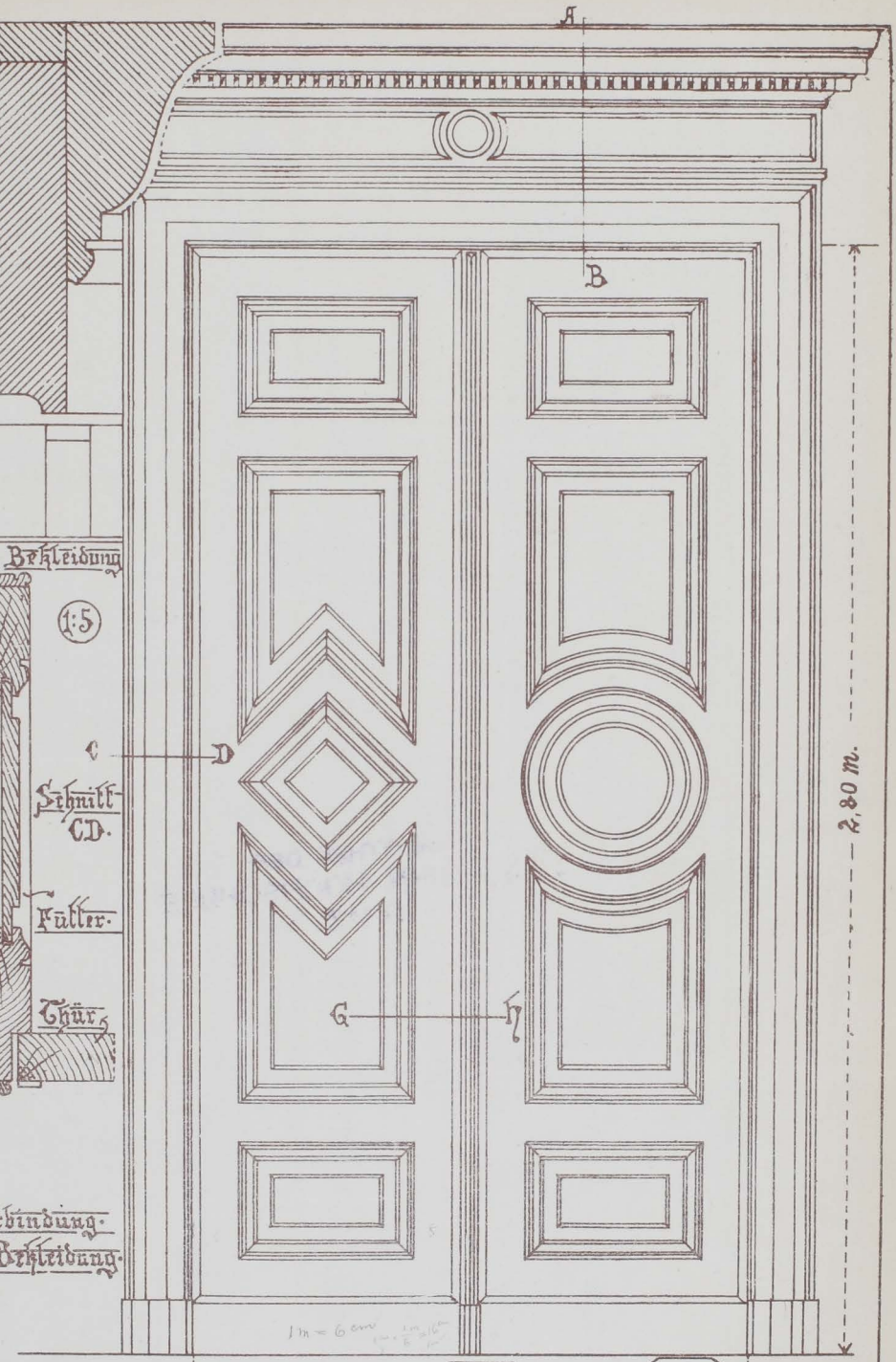

Blatt 10.

1:6

Schiebetür
mit Beschlag
Details 1:6

BeKrönung einer
inneren Thür.

1:6

Schnitt
e-f

Schnitt d-b

Garnituren

Schnitt
g-h

1:6

Schnitt a-b

Anschluss
an den Fuß

isboden

1:6

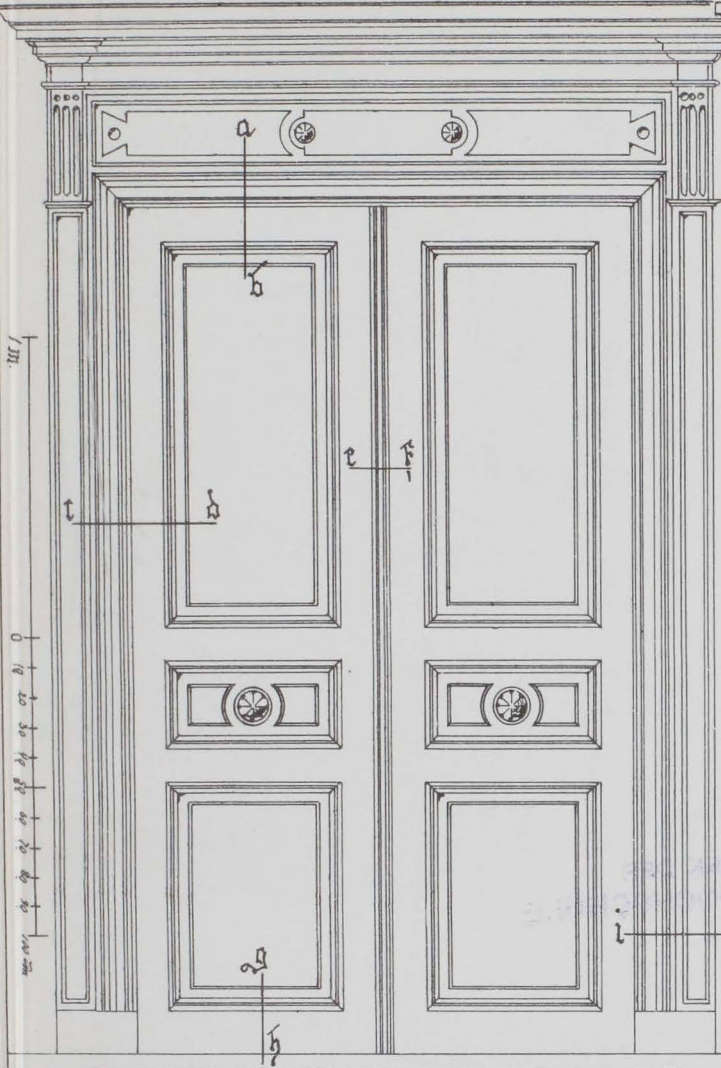

Vertical dimension scale on the left side of the drawing, ranging from 0 to 100 cm.

Grundriss

Schnitt i-k

1:3

Ansicht der Schiene u. Rollen

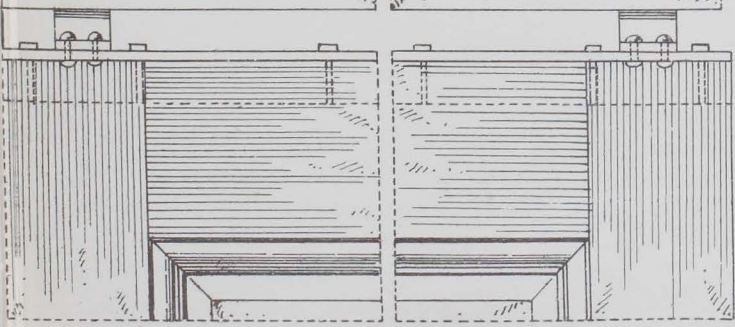

1:20

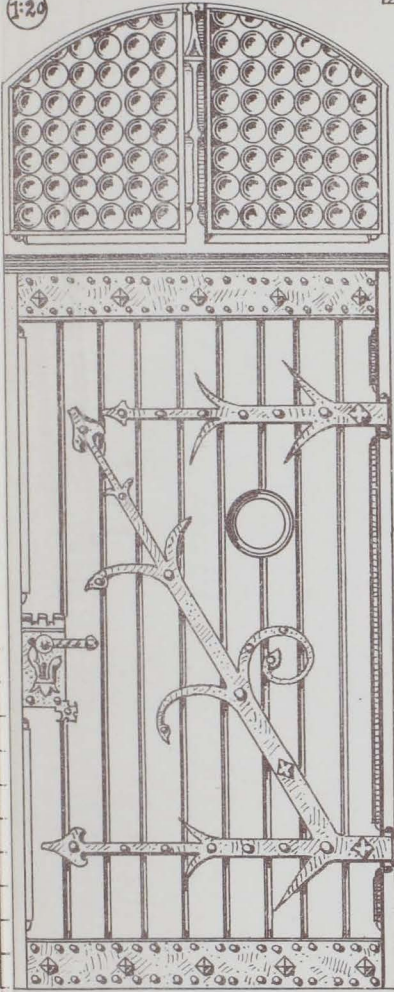

1:15

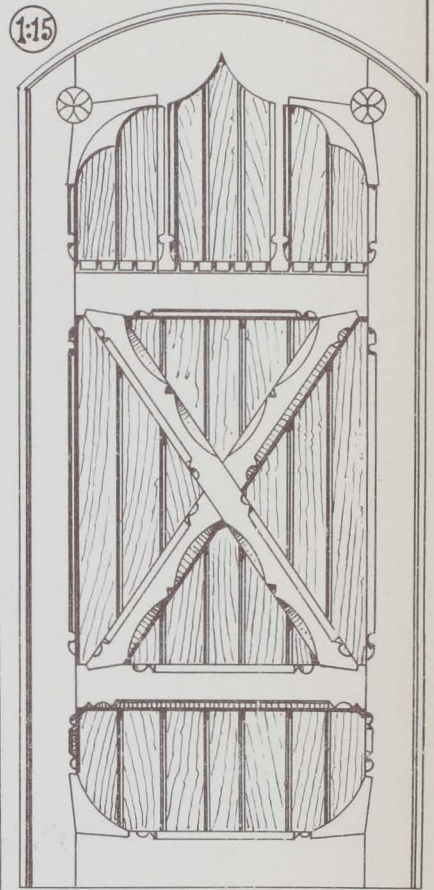

Fussenthür zur Sparlanerstraße
Döhrenerthurm bei Hannover.

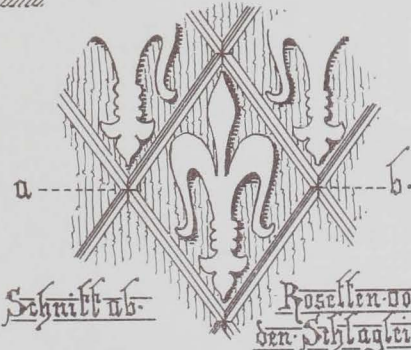
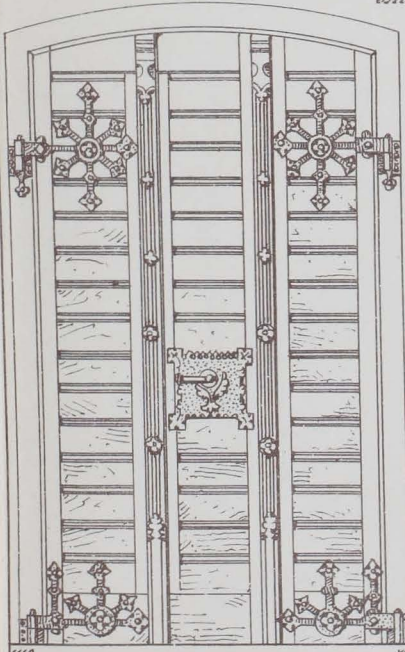

Schnitt ab
Rosellen von den Schlagleisten.

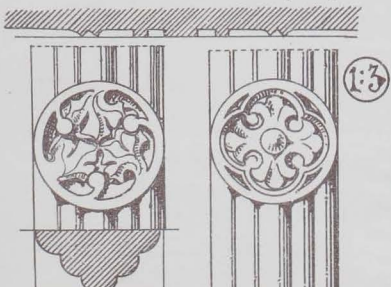

Thür für vom Wohnhaus des
Baurath. Just. in Hannover.

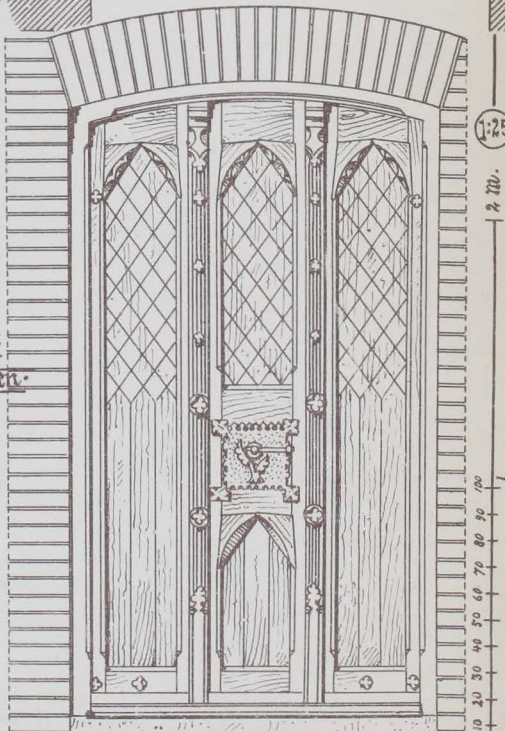

1:25

2 W.

10 20 30 40 50 60 70 80 90 100

Innere Ansicht

Aussere Ansicht

Mayer. autogr.

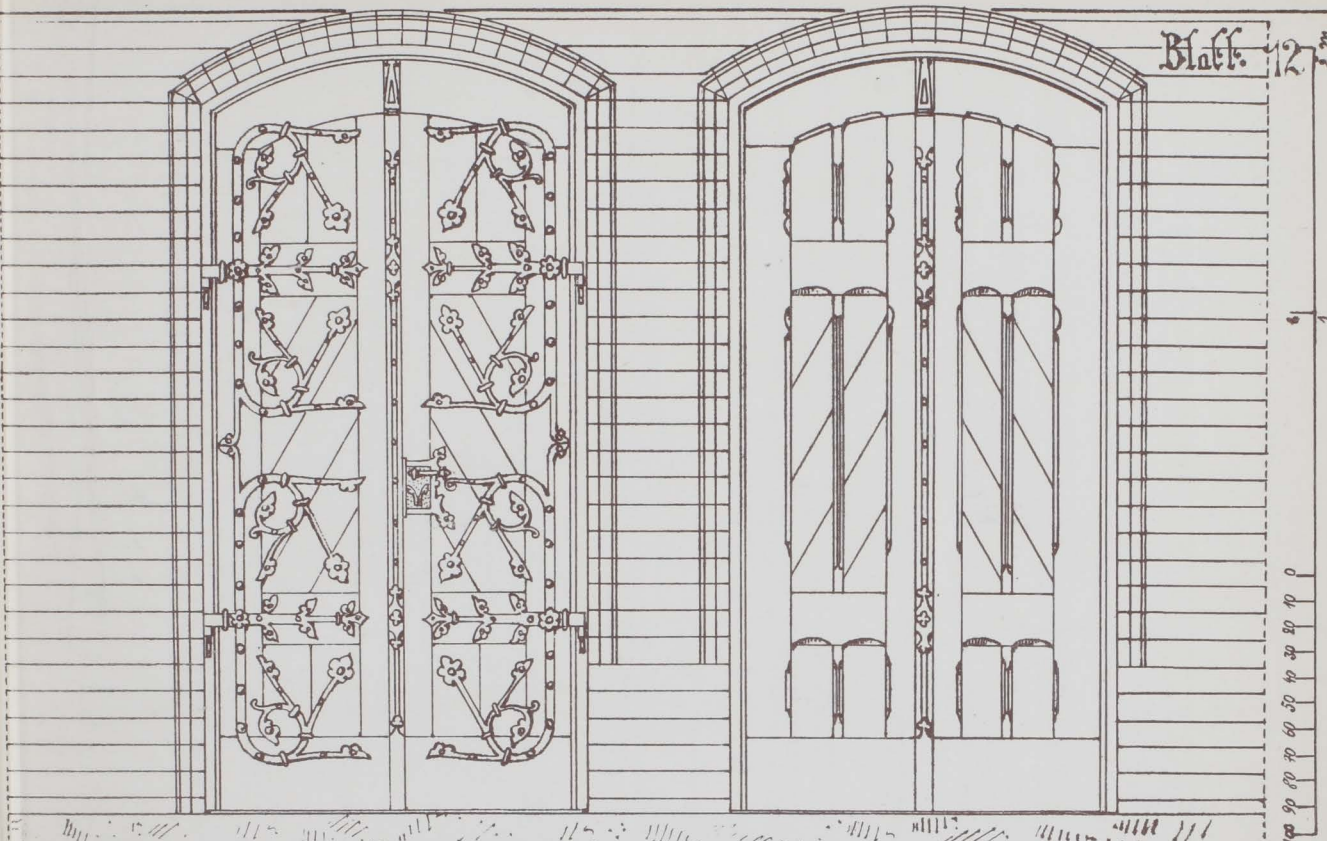

Verbindung bei A. 15

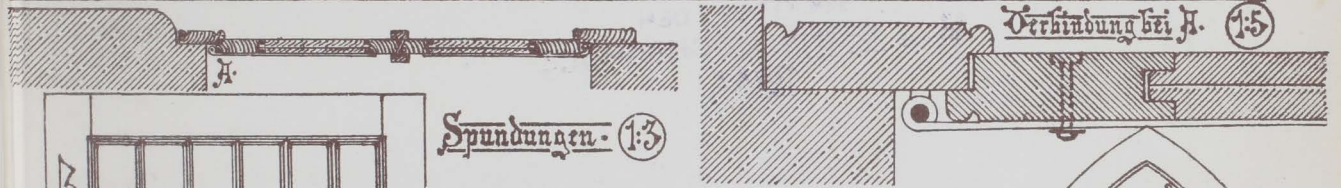

Spundungen. 13

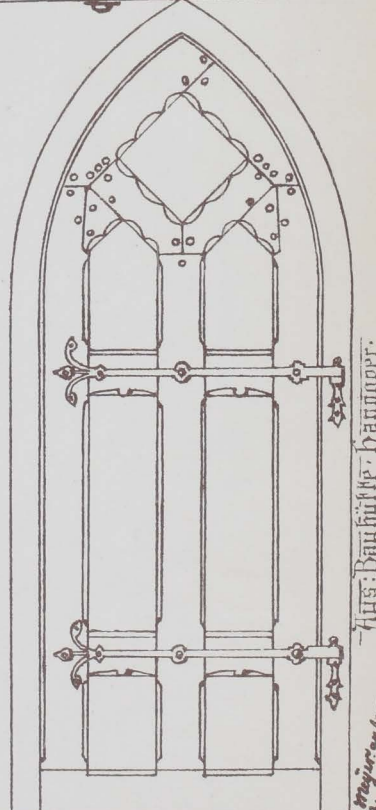
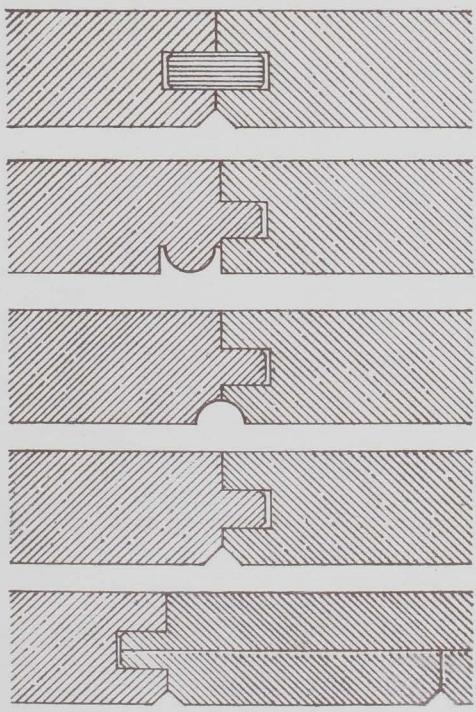
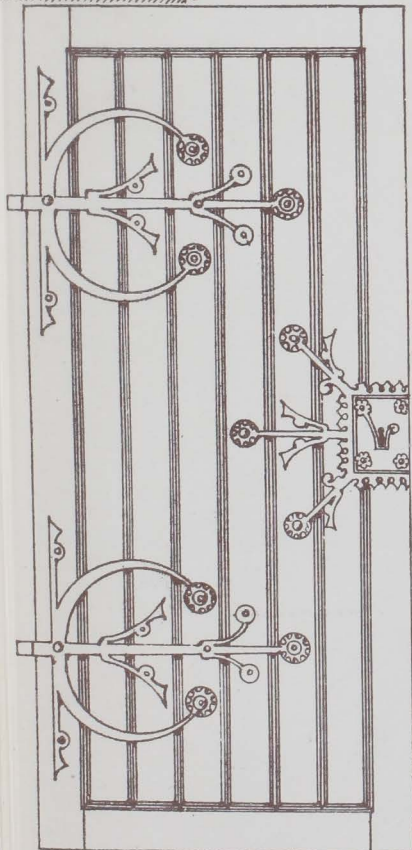

Haus-Bauhütte-Darmstadt
Königsplatz
No. 10

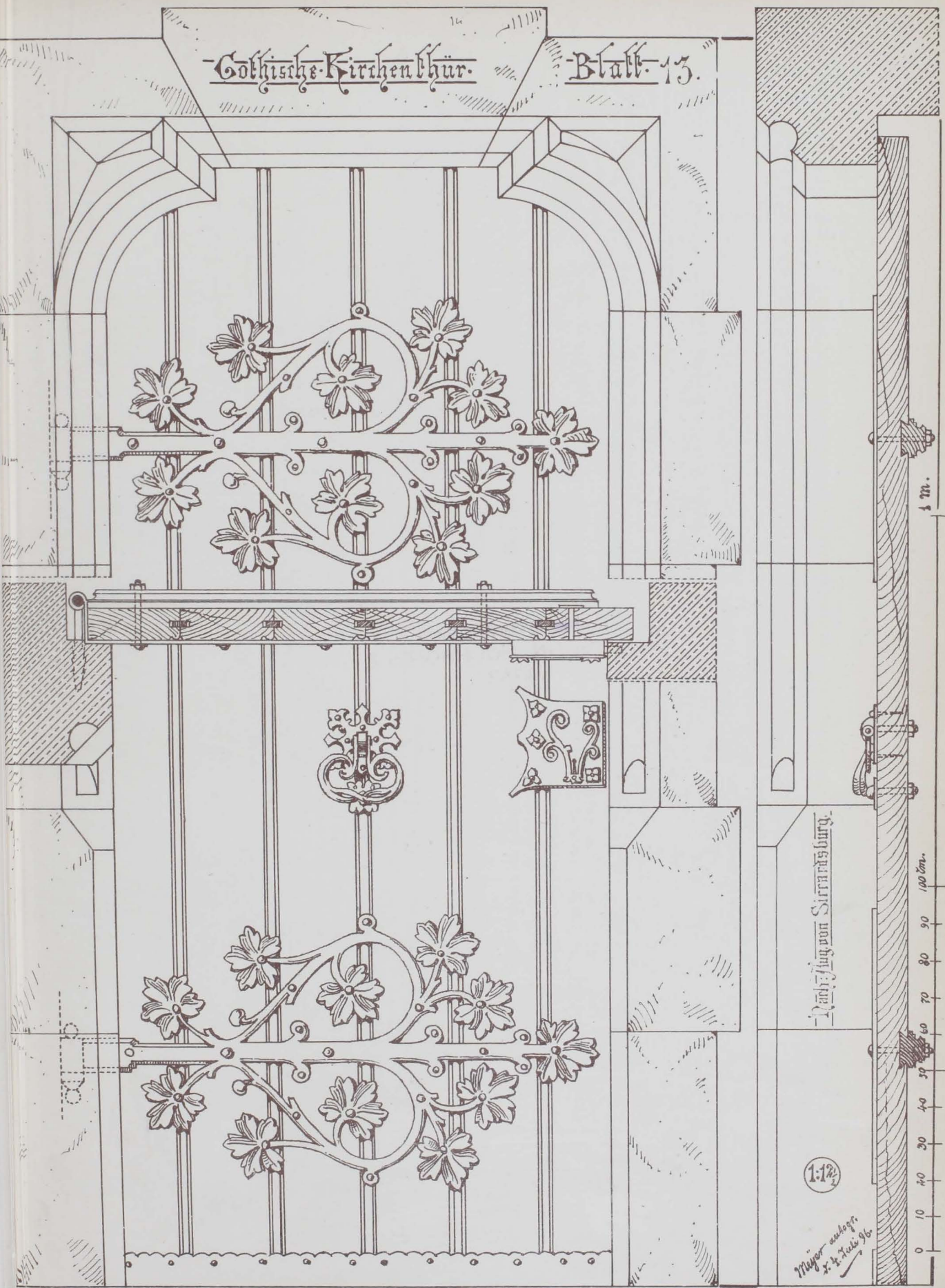

Herrn Jung von Sarrasburg.

1:1/2

Meyer
2. Teil 96

1 m.

100 cm.

90

80

70

60

50

40

30

20

10

0

Portal - Dach

aussen-aufschlagende.

Haus für ein Schul-

gebäude.

Blatt 14.

Detaile hierzu auf Bl. 15.

Prof. H. H. Charlottenburg
entw.

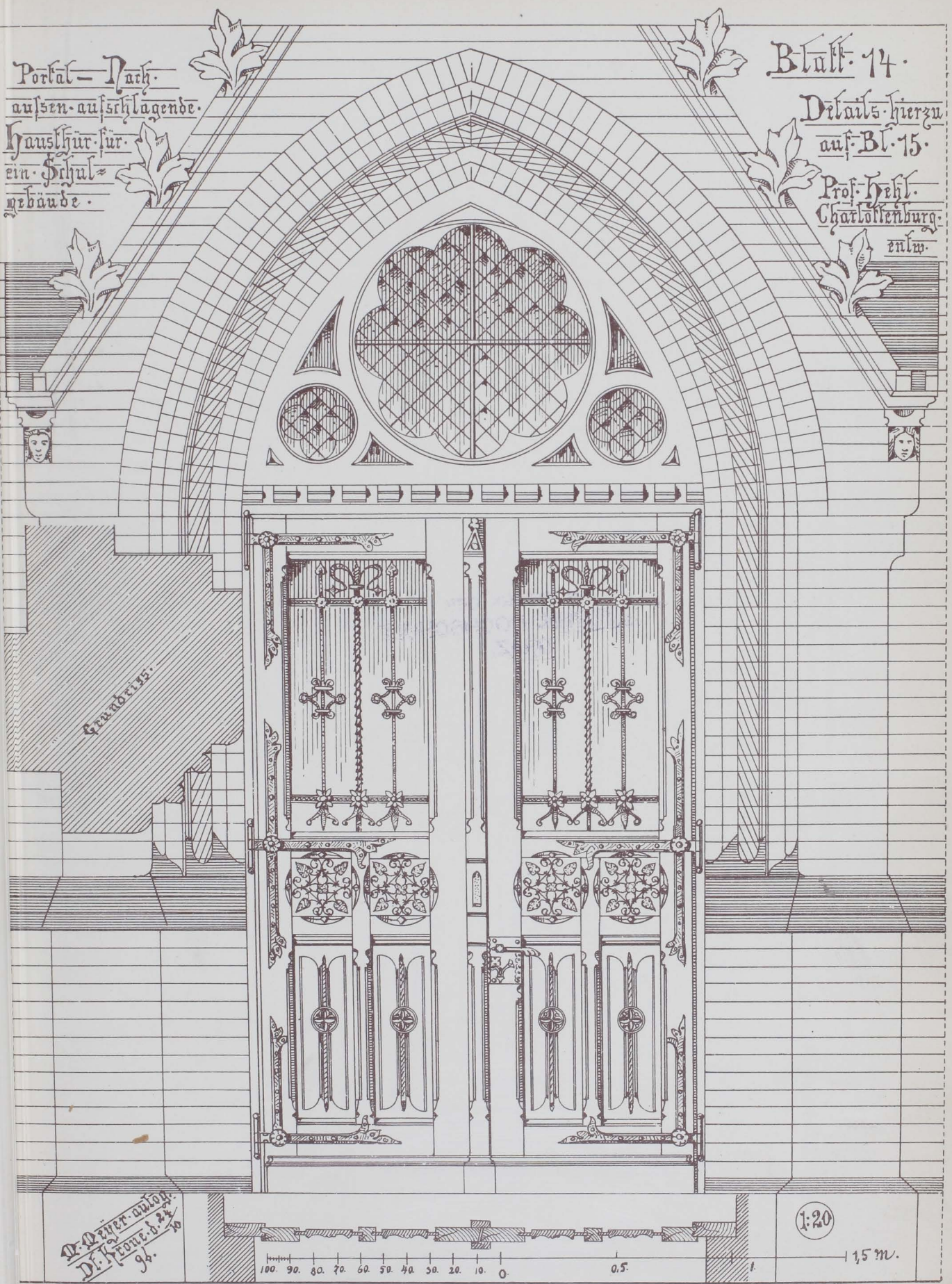

Grundriß

Dr. Meyer anst.
Dr. K. v. d. ...
96.

100 90 80 70 60 50 40 30 20 10 0

0.5

1:20

1,5 m.

Blatt: 15.

Oberlicht.

15

Schnitt
durch das
Kreuzholz.

15

Detail zu der Haustür auf Blatt: 14.

Meyer u. Partner
d. 18/10
96.

50 cm.
140
120
100
80
60

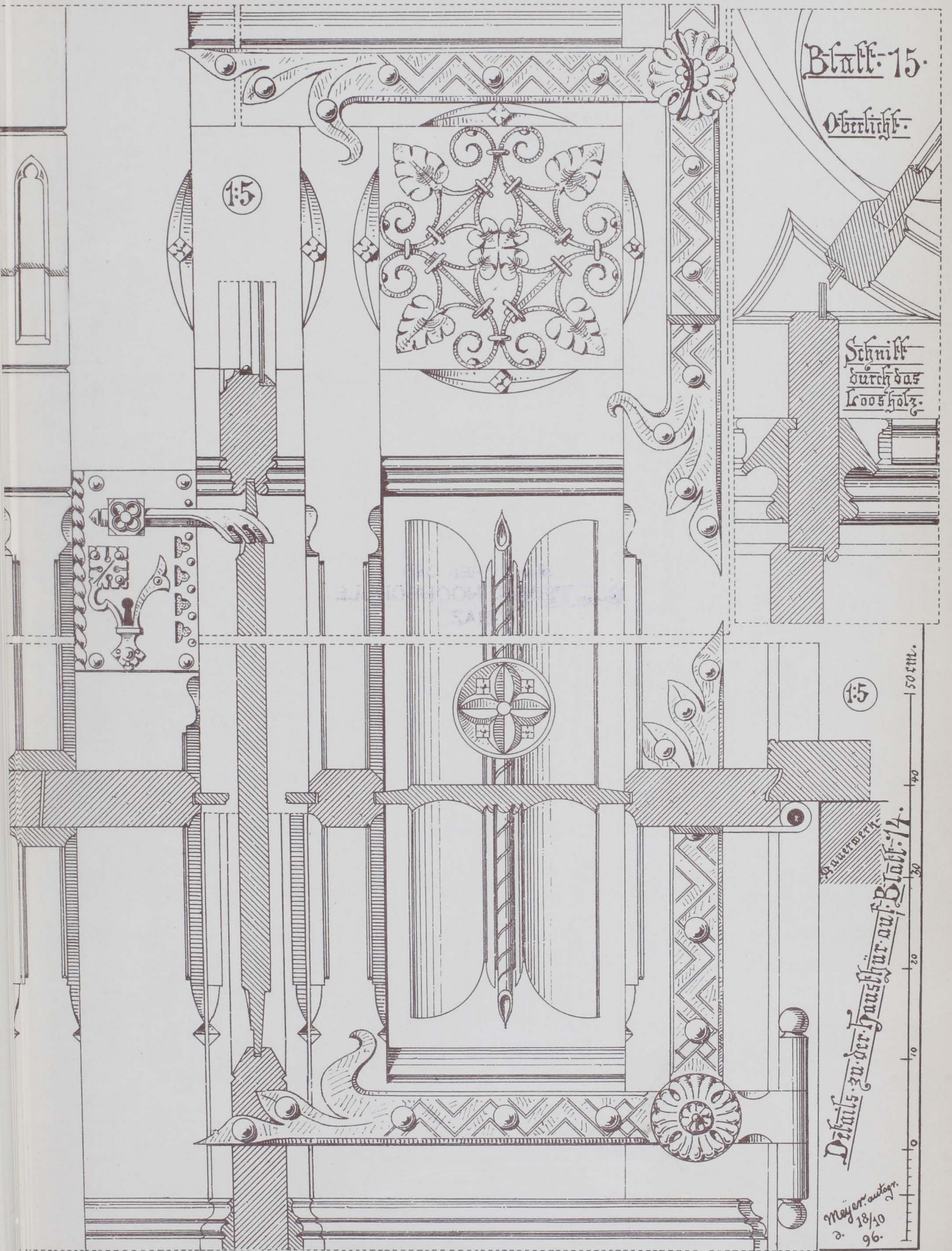

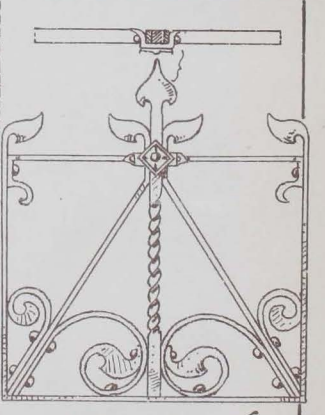
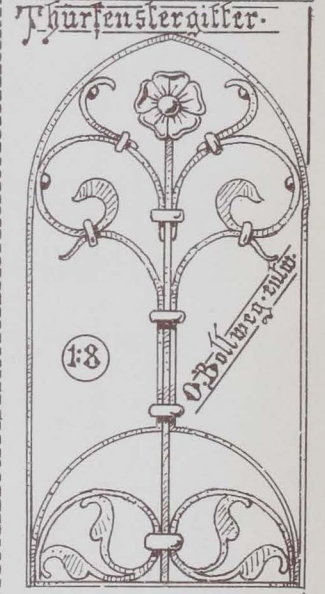
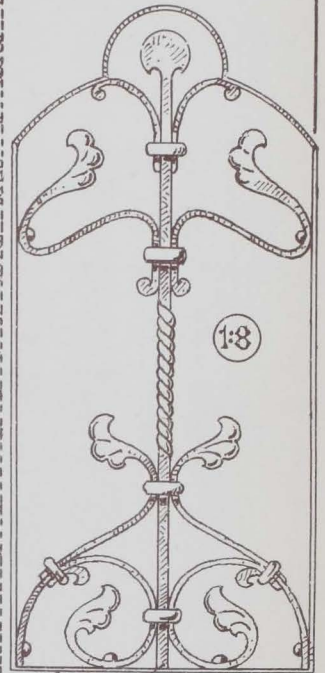

Thürfenstergitter.

Kerbschnitt.

Schnitt Lu.

1:4

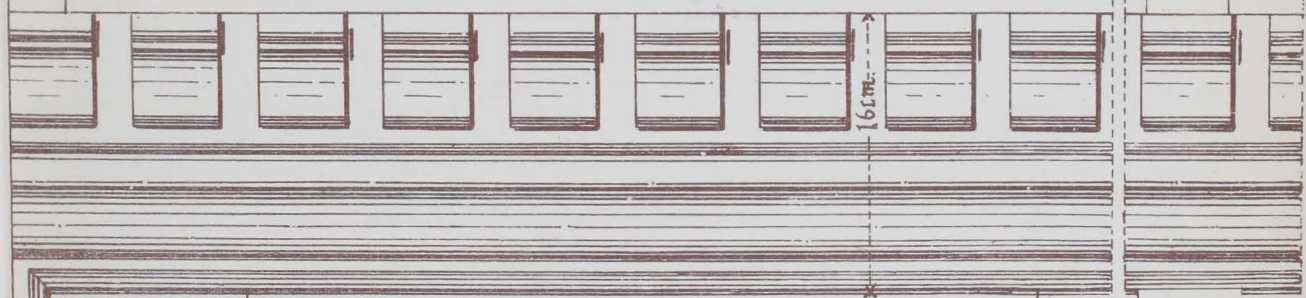

16cm.

12cm.

47.5cm

17cm.

Schnitt no.

Details der Haustür auf Blatt 16.

1:4

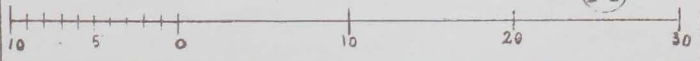

W. Meyer ausleg.

Details zu Blatt: 16.

Schnitt ab

1:4

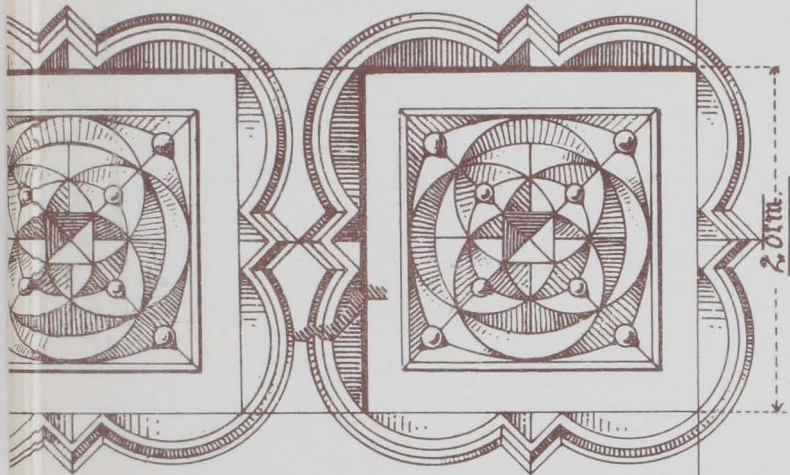

20 cm

40 cm.
30
20
15
10
5
0
5
10

Schnitt c

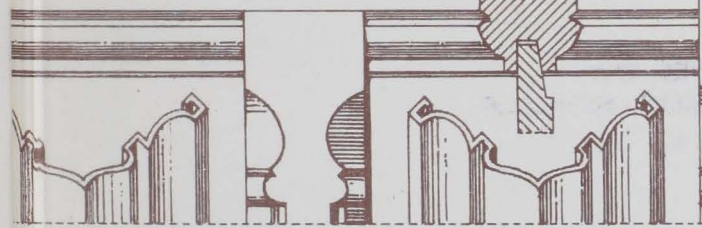

20 cm

20 cm

Schnitt e

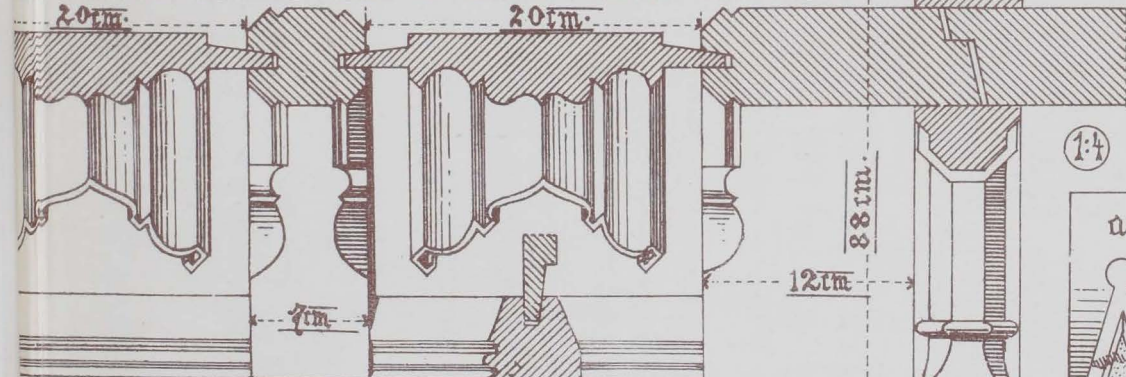

20 cm

20 cm

88 cm
12 cm

1:4

Kämpfer

Schnitt h

1:4



a.

b.

Schlagstein a u. b.

Schnitt g

Socht. 12

Steinschwelle

Fußboden

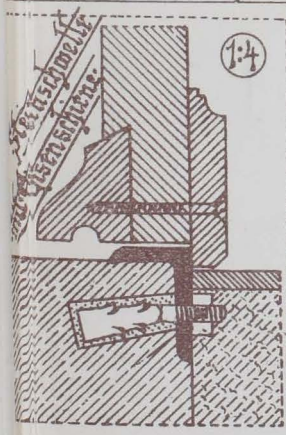

1:4

Steinschwelle
12 cm Socht.

Meißner autogr. den 3. Jan. 98.

Haupt-Eingangstür. Blatt 19
 der Katholischen Bürgerschule
 zu Hannover. entw. v.
 Prof. Hehl.



Maßstab 1:20.

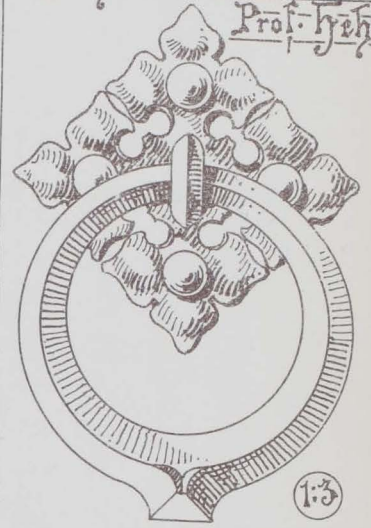

1:3

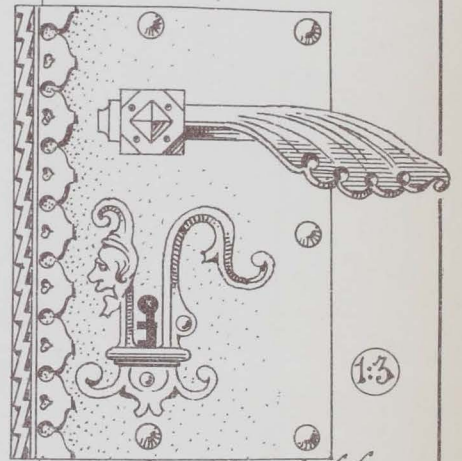

1:3

Gothische Schlüsselschilder.

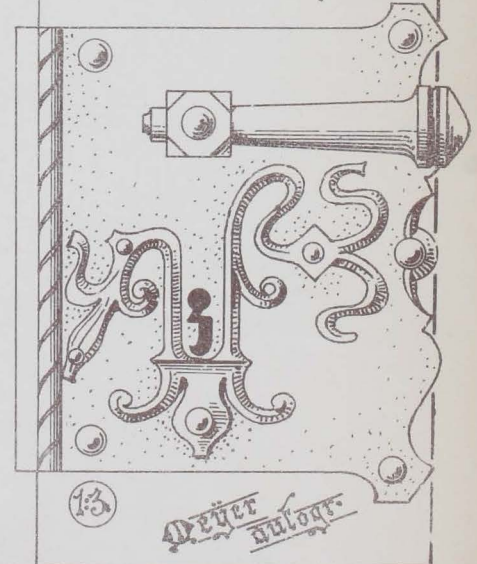

1:3

Deiter
 autogr.

Details zu der Haustür.
auf Blatt 19.

Blatt 20.

1:4

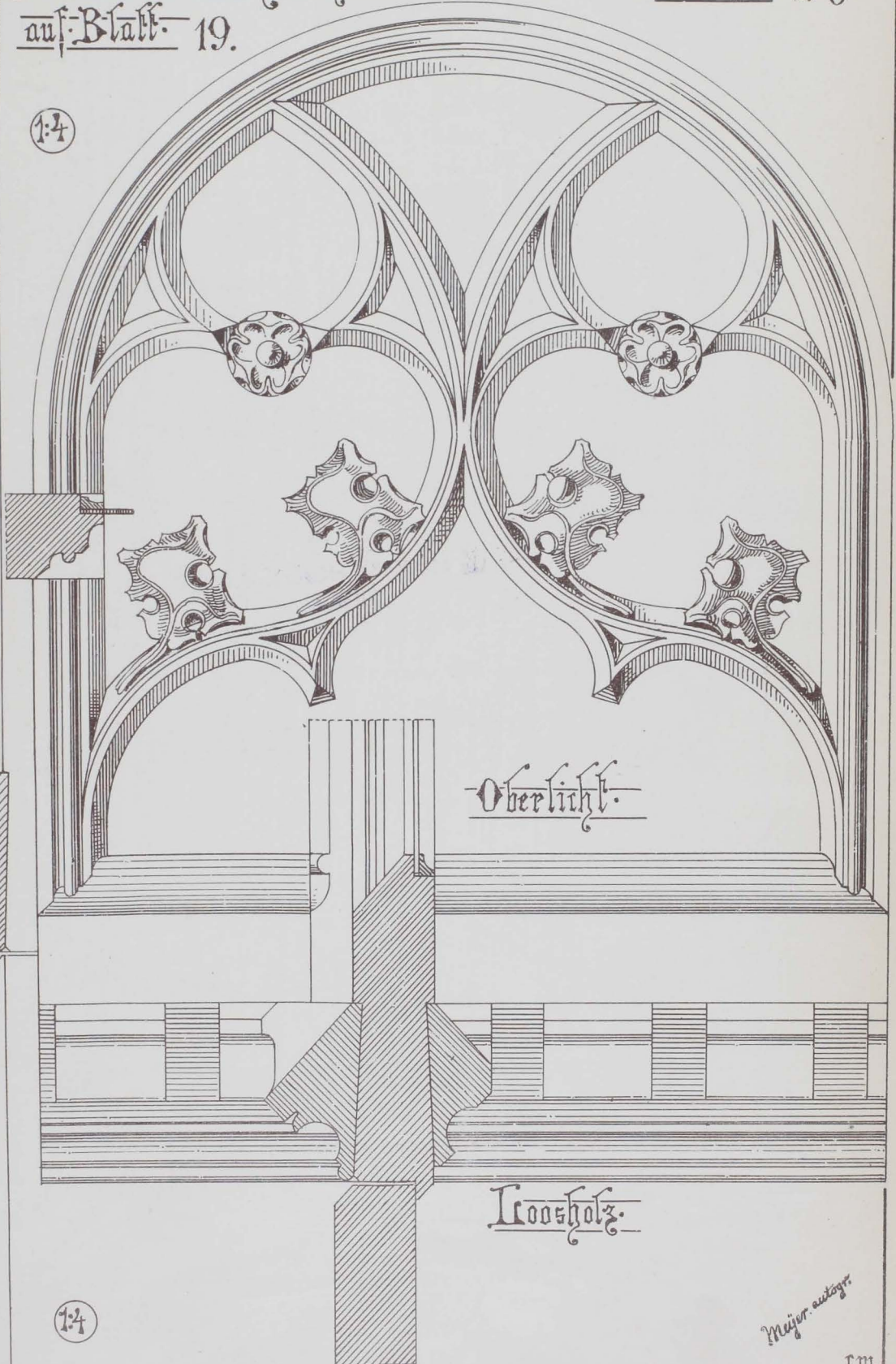

Oberlicht.

Kreuzholz.

1:4

Schlagriste.

10 9 8 7 6 5 4 3 2 1 0

10

20

30

40

50

Mejer. autogr.

Schloßblech
und Drücker
1:3. d. nat. Gr.

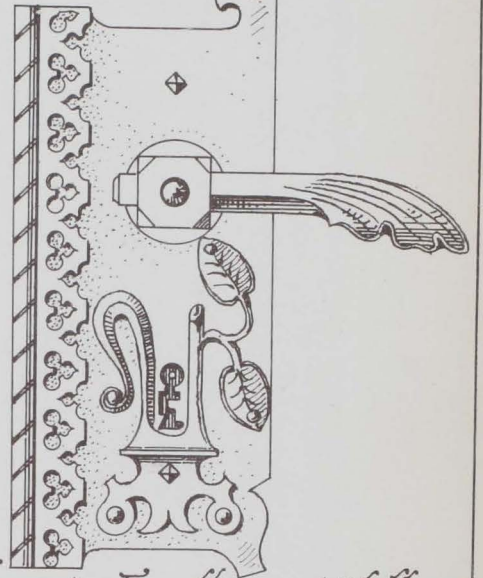

Details zu der Hausthür auf Blatt 19

Schlagziele

Schnitt durch Rahmen und

Rückung

1:4

10 9 8 7 6 5 4 3 2 1 0 10 20 30 cm.

Vorderansicht

Seitenaussicht

Deger anlage
d. 22. Nov. 96

Heilverbindung bei H.

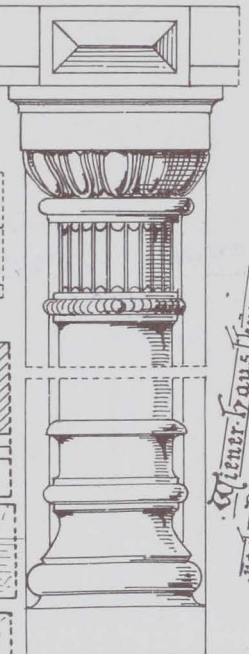
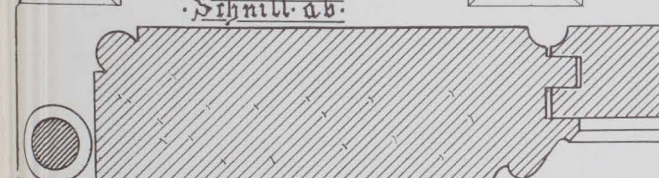
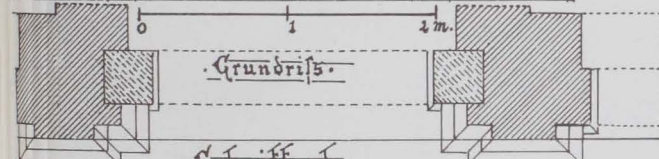
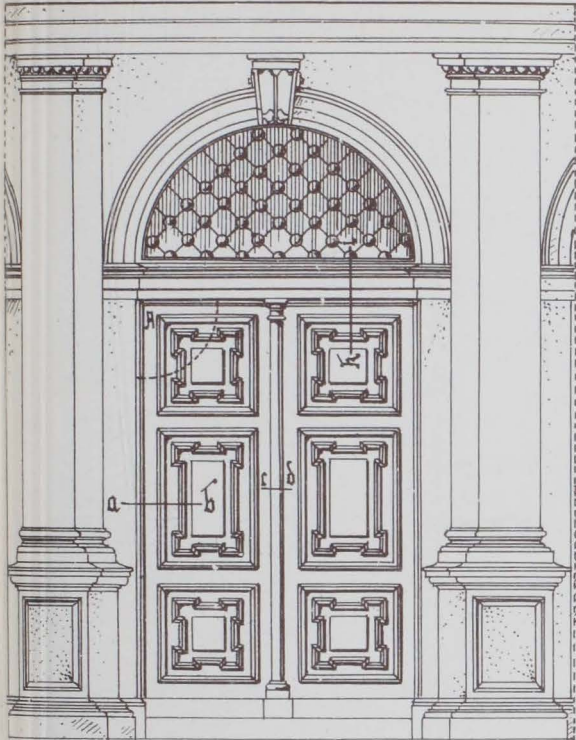

Grienerhaus Thür.
nach Weyher u. Schmidt.

Französische Heilverbindung.

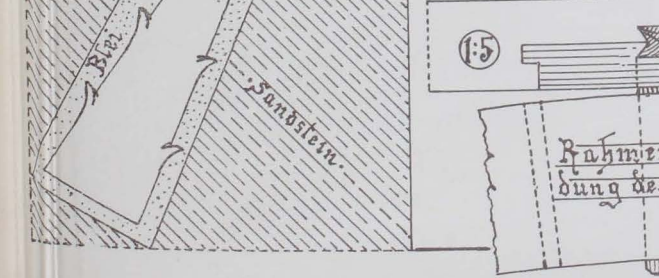
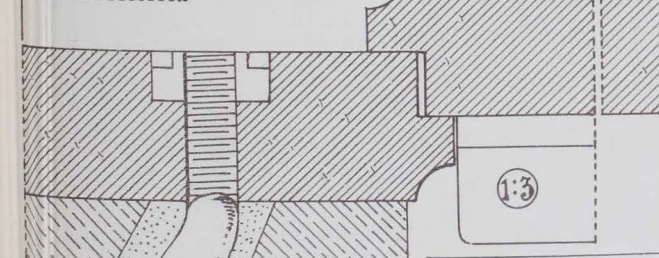
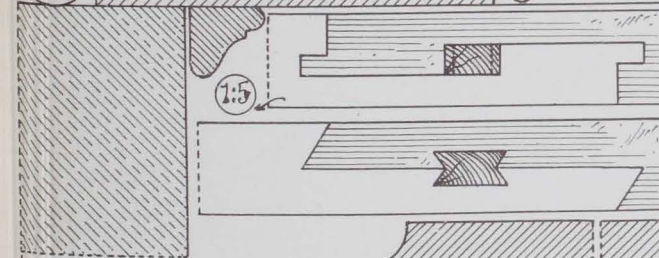

Rahmeverbindung des Oberlichtes

Schnitt. i.d.

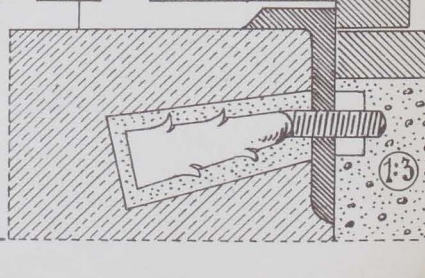
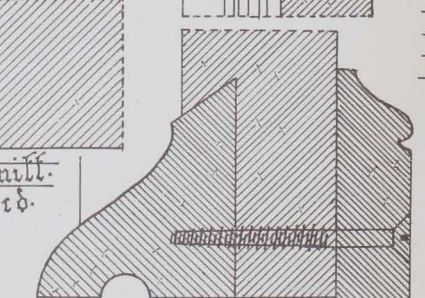

30 cm.
20
10
0 1 2 3 4 5 6 7 8 9 10

Längsschnitt.

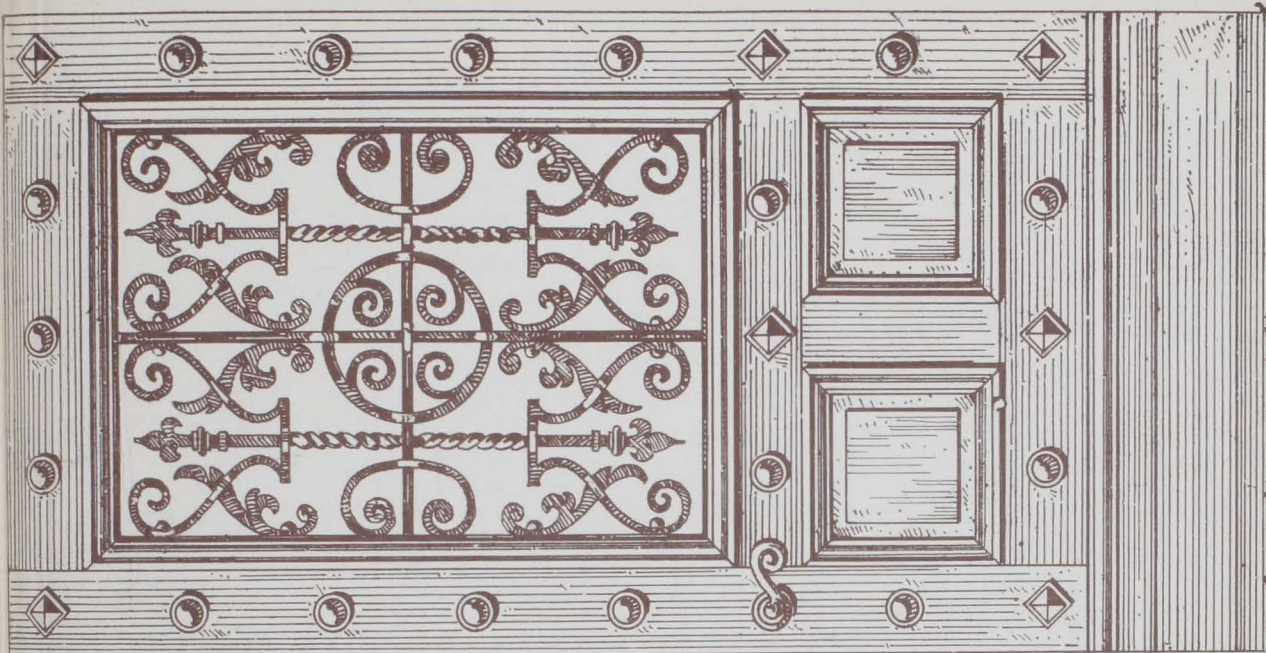

Souffran hüren im Schloss Hummelshain.
 Arch. Thne u. Stenmüller. Arch. Skizzen buch.

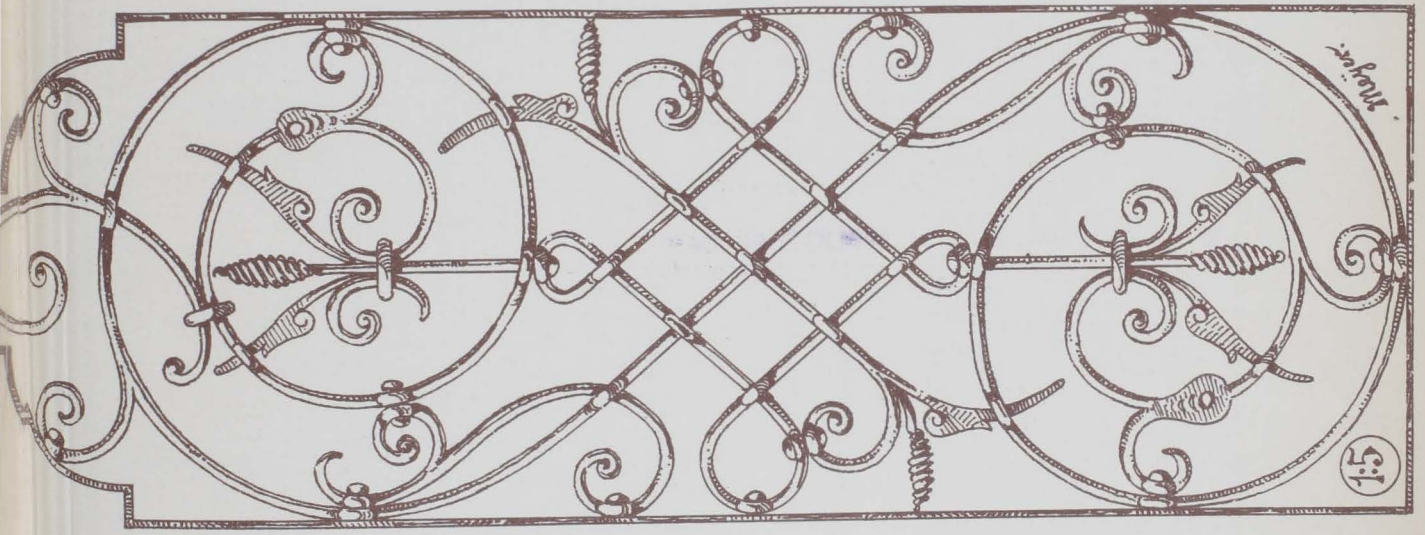

1860

51

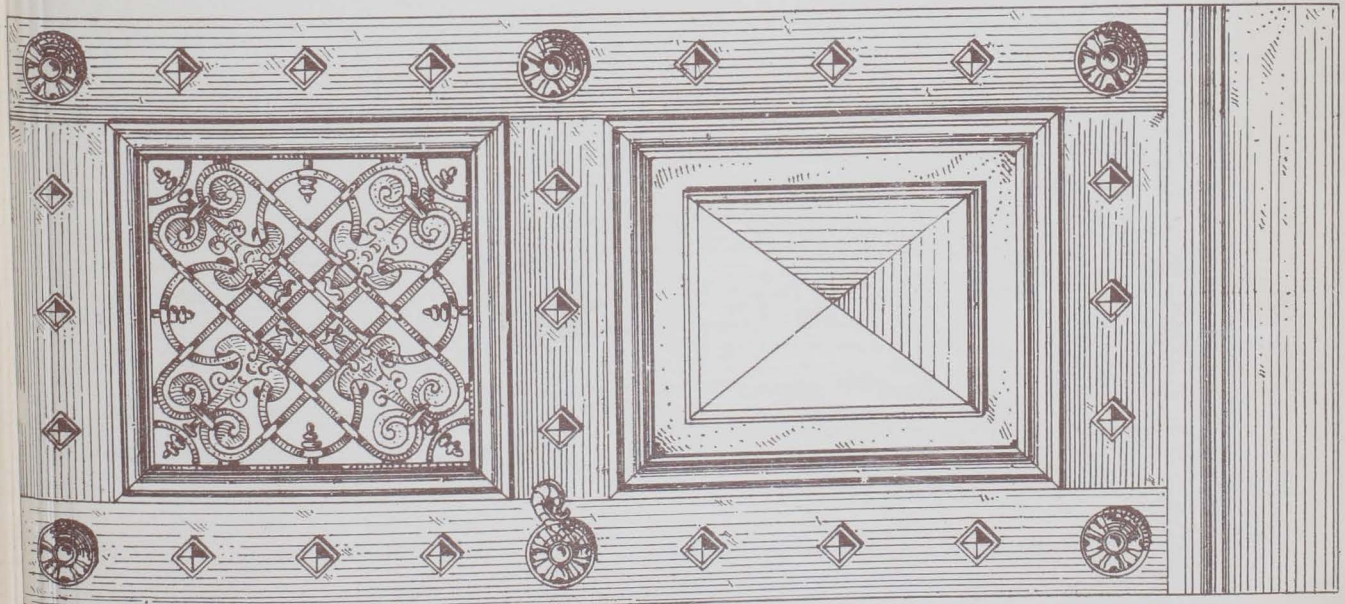

Dreitragige
Stausitur mit
Oberlauf.

Blatt. 24.

10 5 0 10 20 30 40 50 60 70 80 90 100 cm. 1,50

12 m. m. meyer. 5. 3/199.

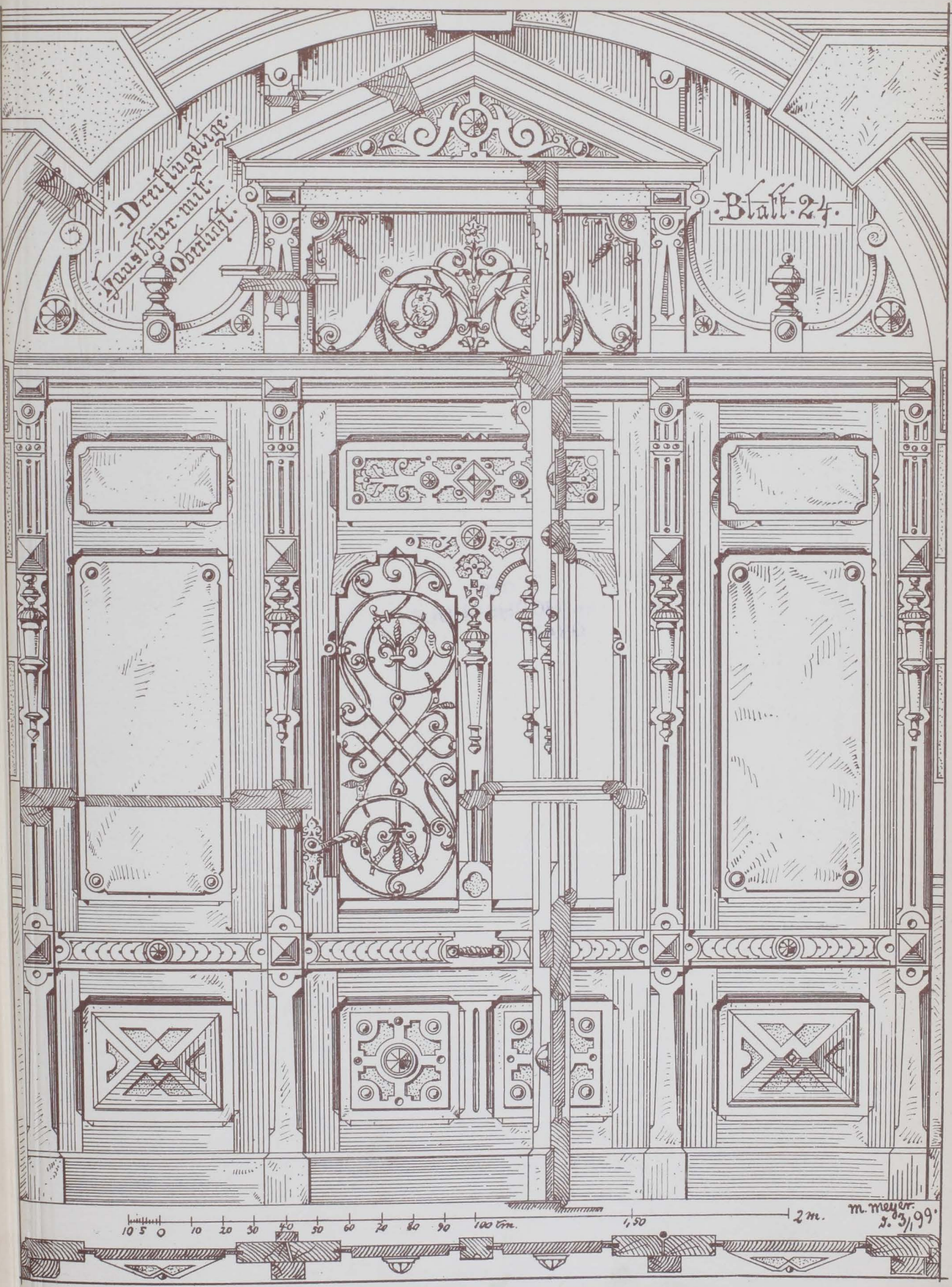

3 m.

Windschutz
tür.

2

100-211.
90.
80.
70.
60.
50.
40.
30.
20.
10.
0.
0-5

Mayer autogr.
Nr. 1. Febr. 99.

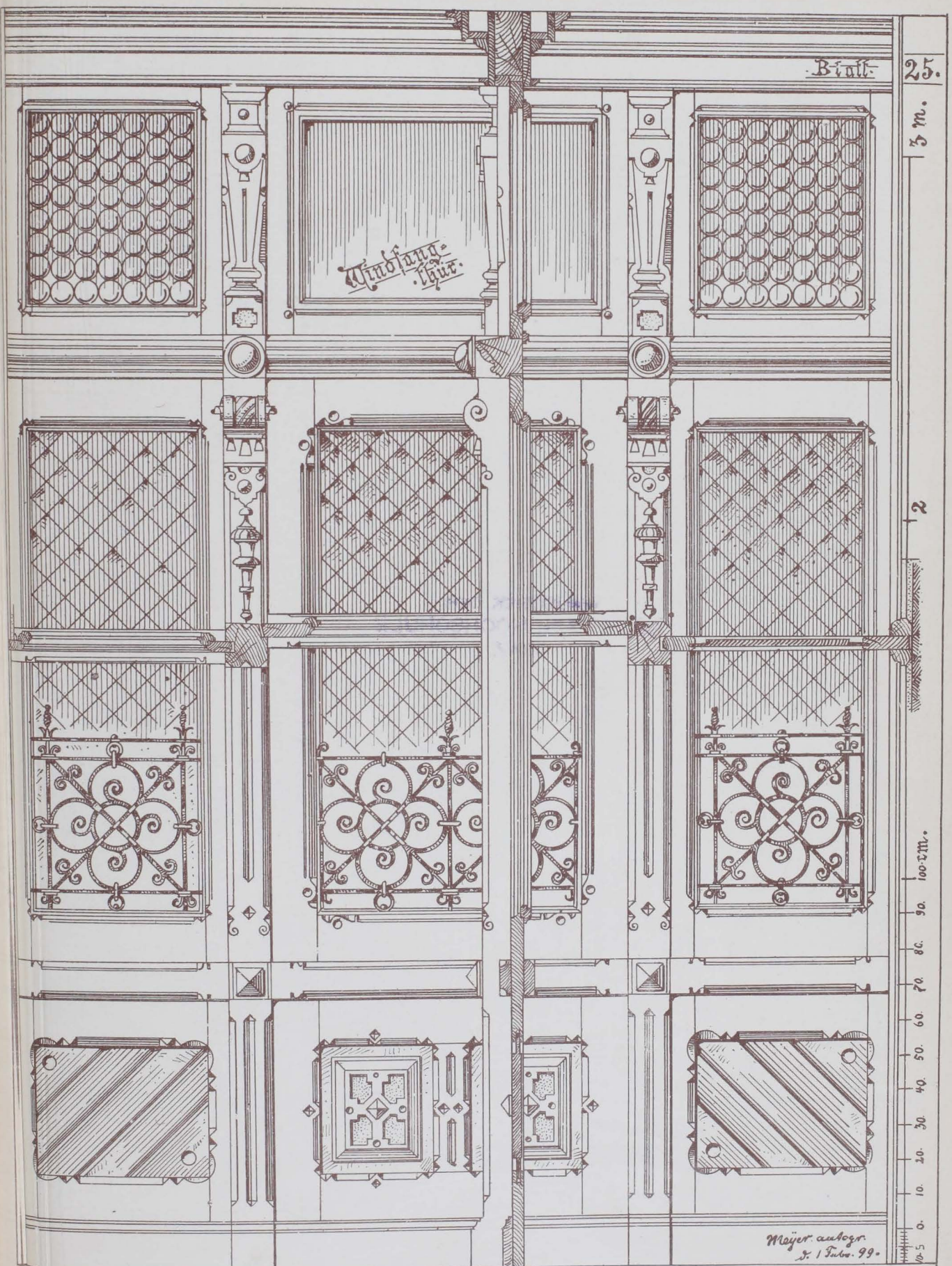

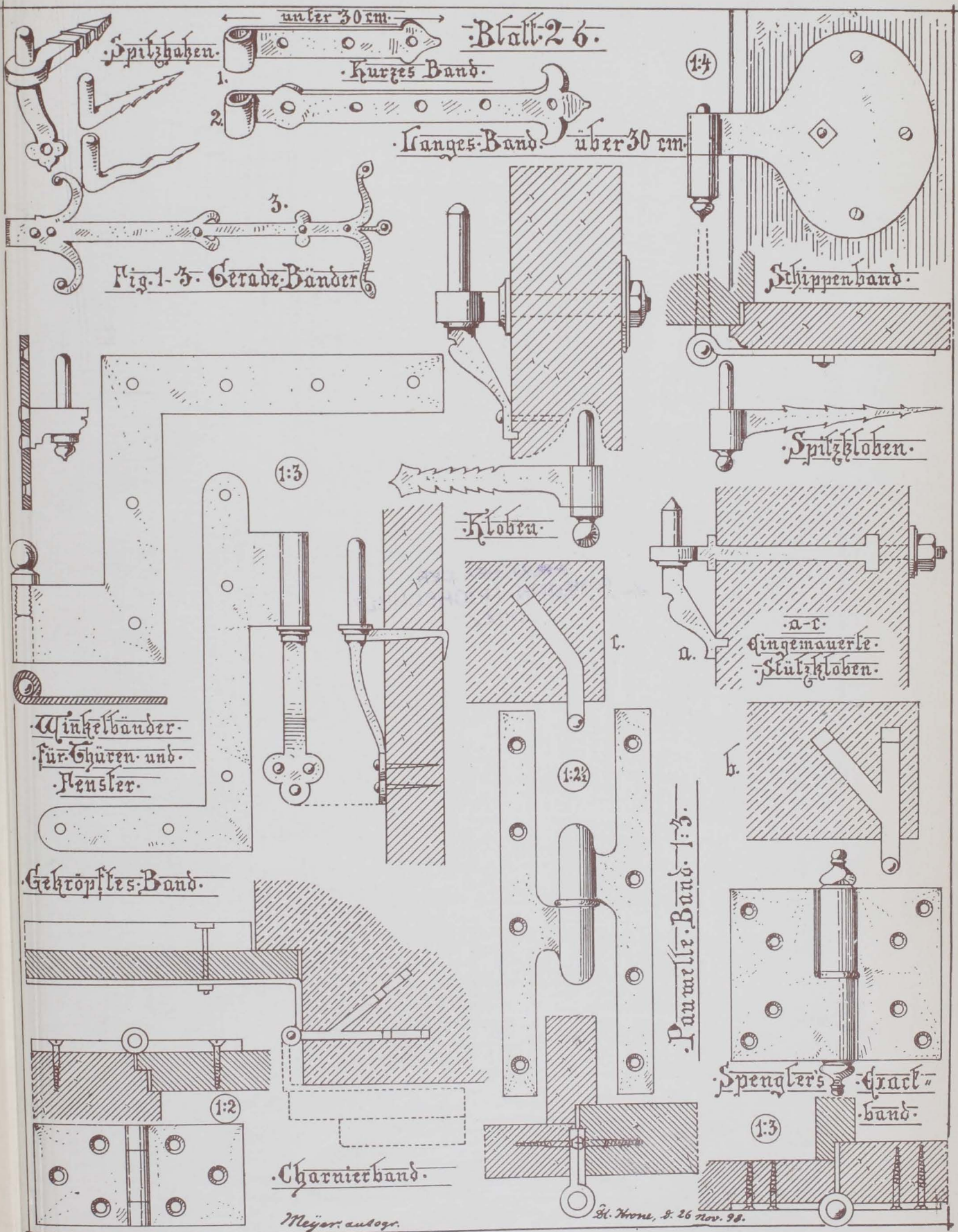

unter 30 cm. Blatt 26.

Spitzhaken. Kurzes Band.

1. 2. Langes Band über 30 cm.

Fig. 1-3. Gerade Bänder.

Schuppenband.

Spitzkloben.

Kloben.

a. c. Eingemauerte Stützklöben.

Winkelbänder für Türen und Fenster.

Geköpfles Band.

Panzerband 1:3.

Spengler's 'Grack' band.

Charnierband.

Meyer, autogr.

St. Trone, 8. 26 Nov. 98.

Aufsatzband. od. Fischband. für Thüren und Fenster.

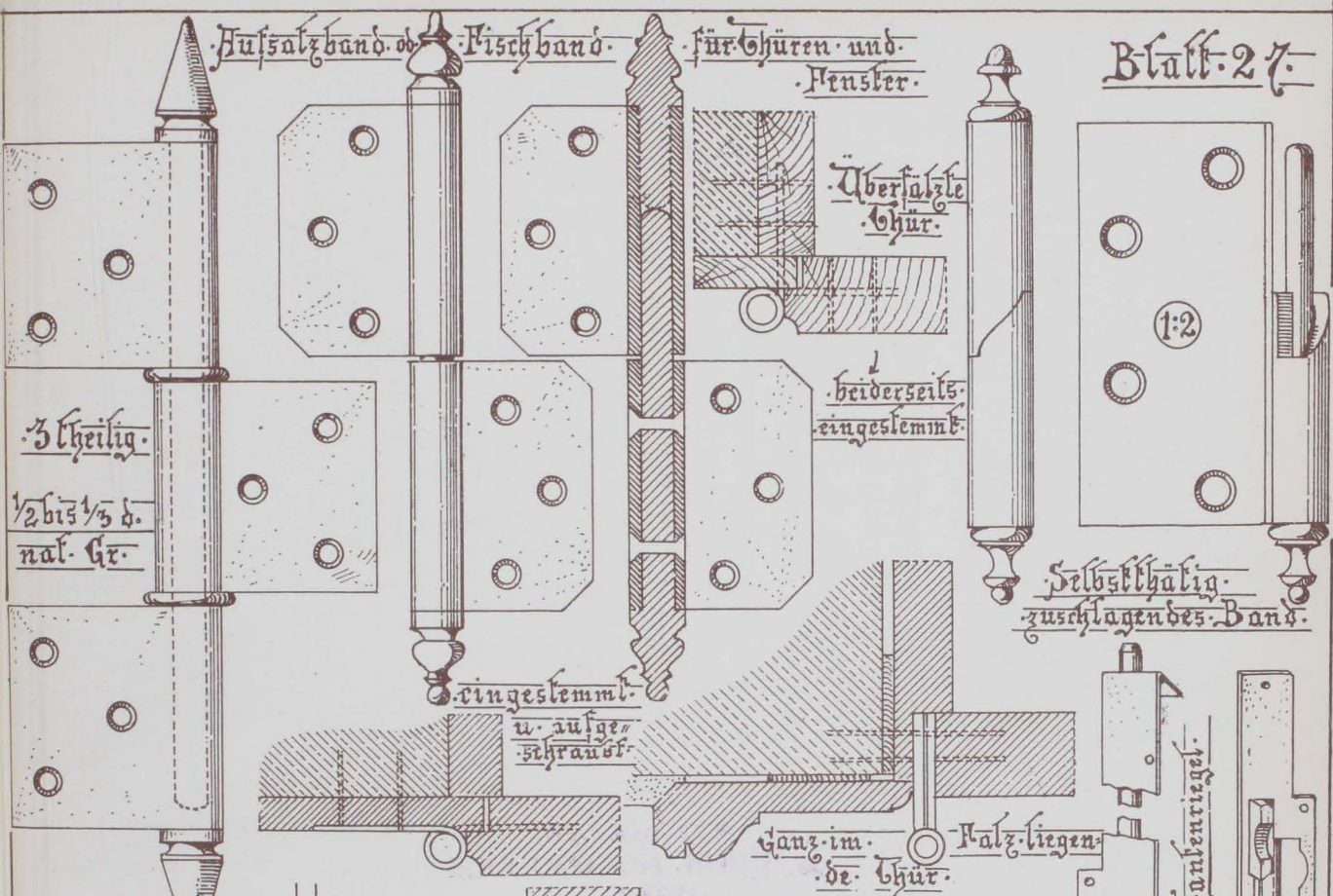

Kreuzband 1:3.

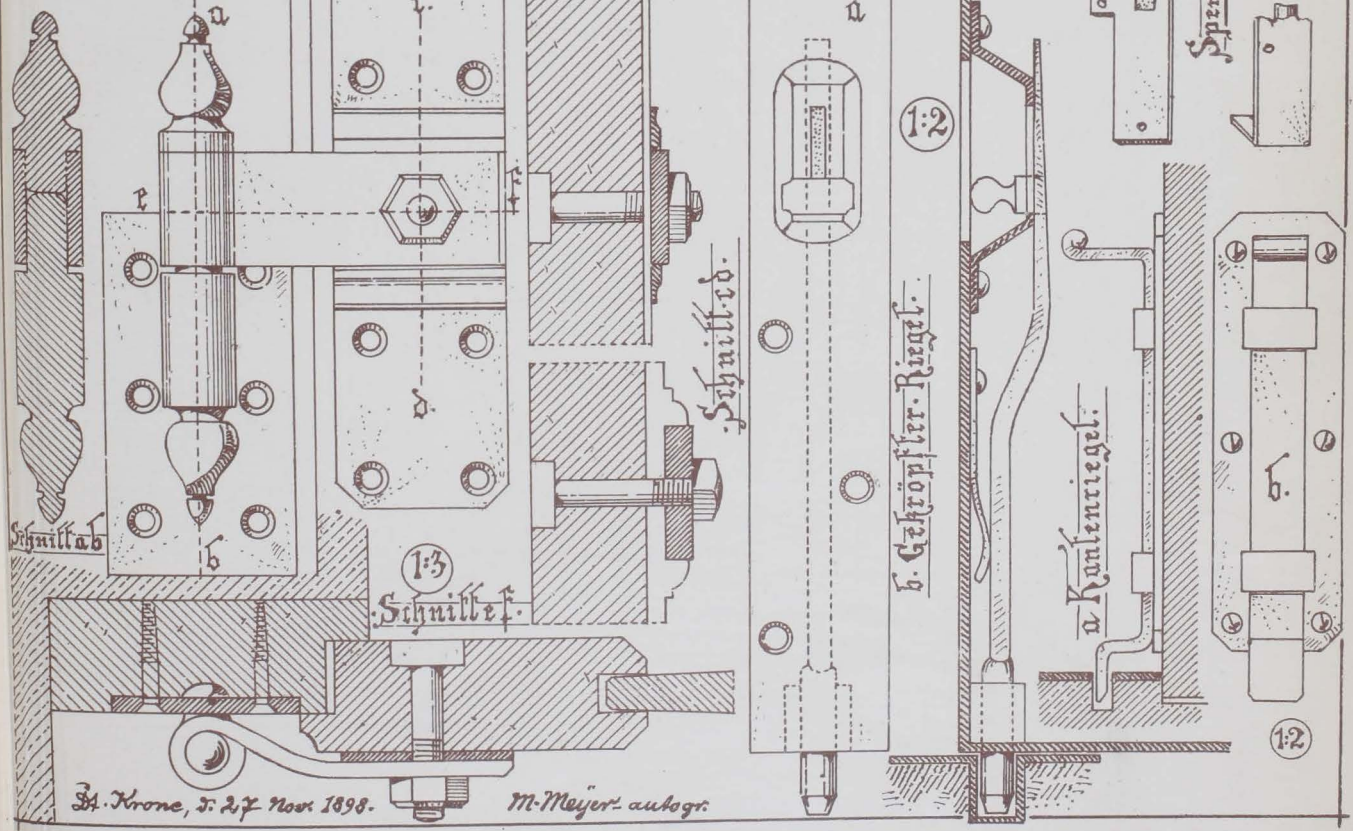

Stiftband für leichte Thüren.

Halsisen.

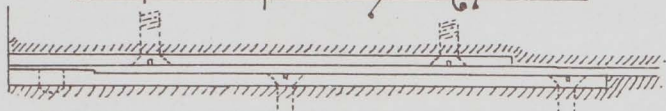

Beschlag einer schweren Thür.

Zurück für schwere Thüre.

Dorn.

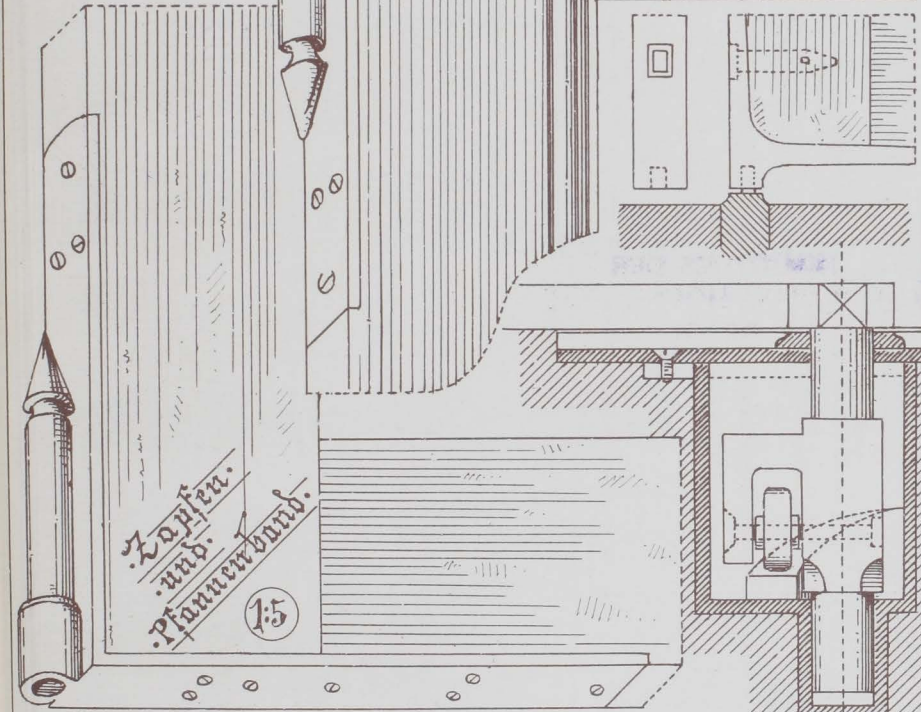
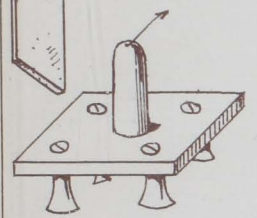

Zapfen und Pfannenband.

15

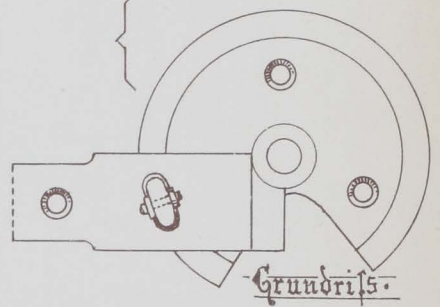
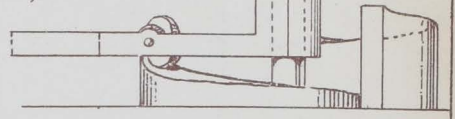

Grundriss.

Pendelbeschlag für Windfangthüren.

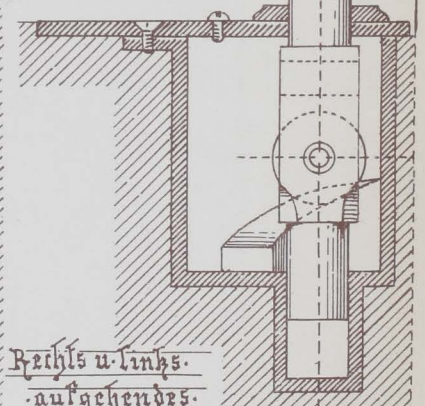

Rechts u. links aufgehendes.

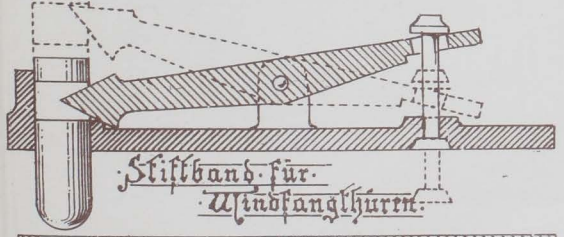

Stiftband für Windfangthüren.

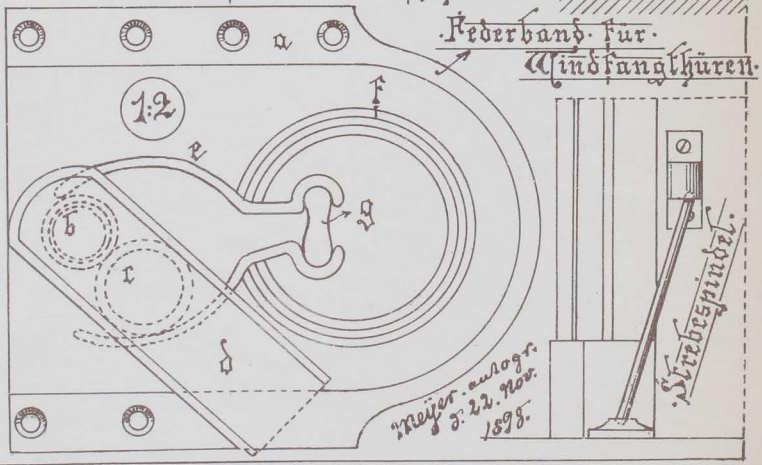

Federband für Windfangthüren.

12

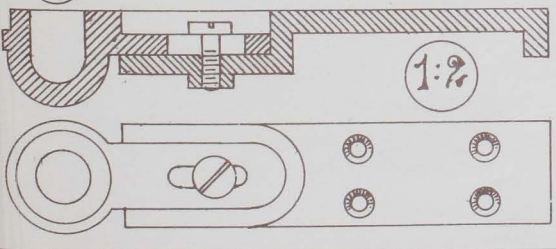

1:2

Strebepindel.

Meiſter. eulog. v. 22. Nov. 1898.

Beschlag eines schweren Schirbellores.

Differential-Schirbelhür-Beschlag.

Blatt 29.

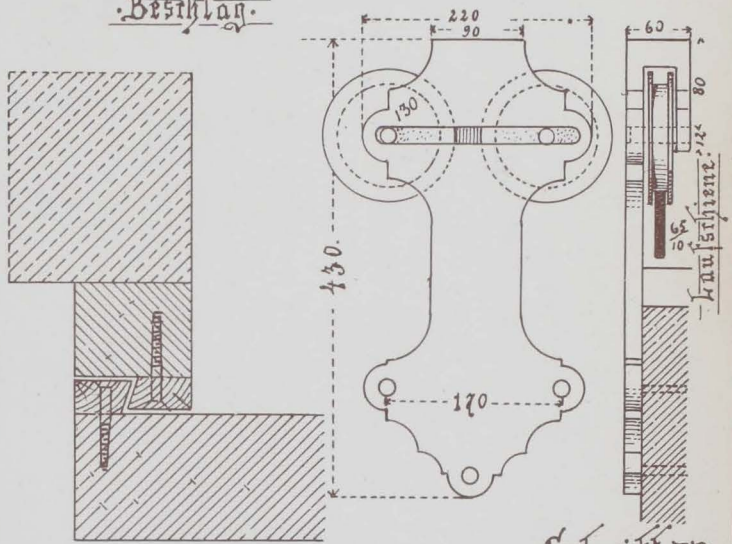
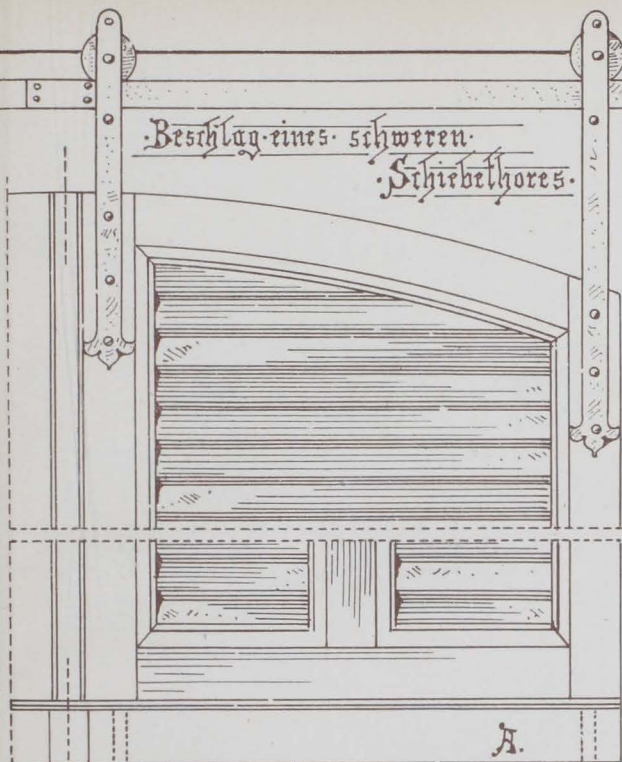

A.

Ansicht

Schnitt. ef.

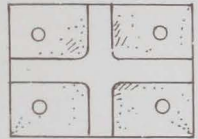

Ansicht der Rolle.

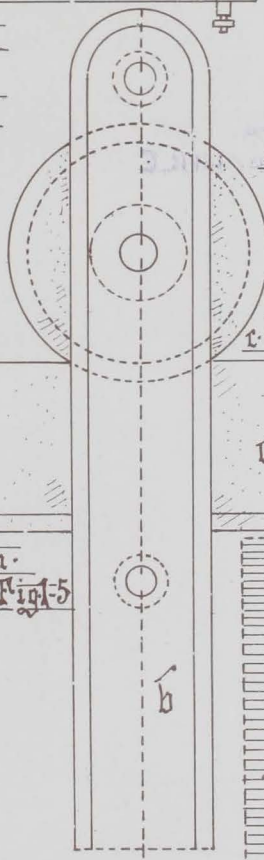

B.

Details.

1:4

a Laufschiene
b Hängerisen
c Gulseiserne Stützen.

a

Dichtungen mit der Wand.

Schnitt AB.

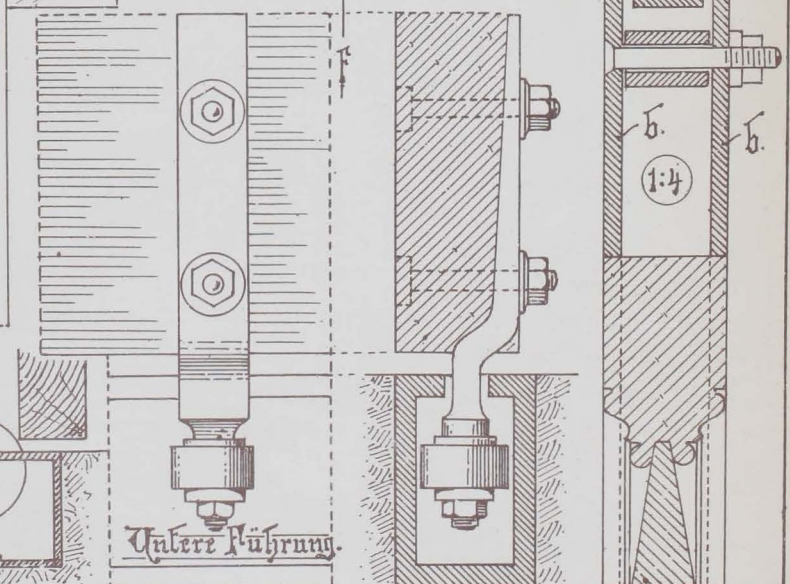

Untere Führung.

Festhaltungen für Chore. Figl-5

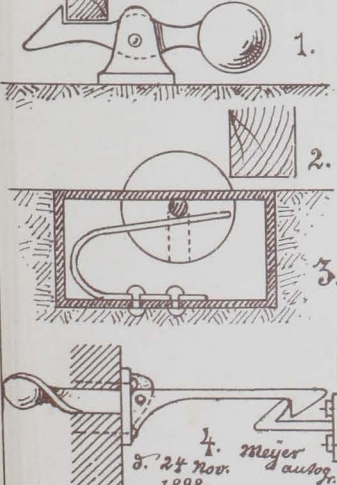

4. Meyer autogr.
d. 24 Nov. 1898.

Schmiedische Beschläge.
aus Hannover.

Fig. 1.

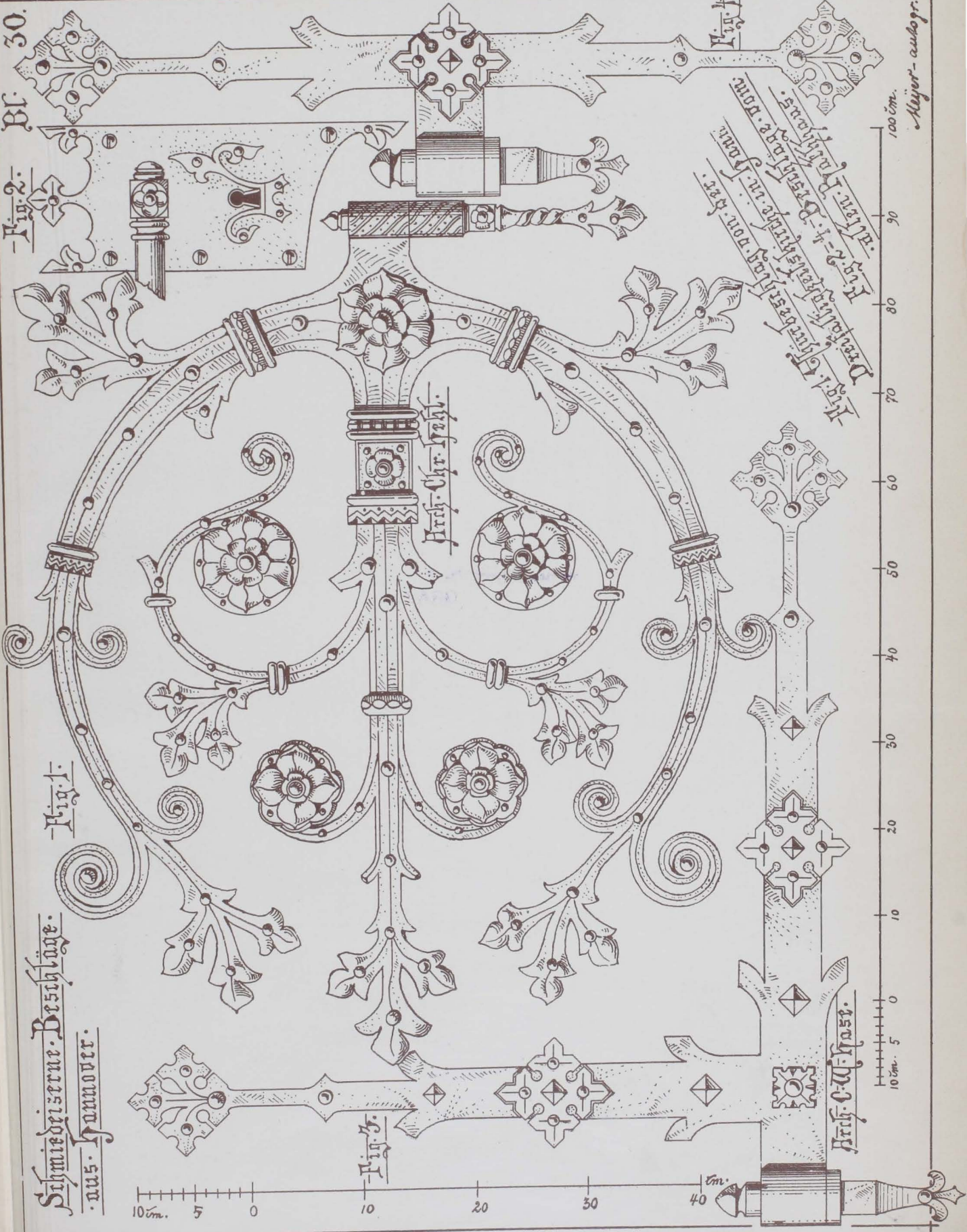

Fig. 2.

Arch. Chr. Sch.

Arch. C. W. Hass.

Fig. 1. Eisenbeschlag von der
Dreifachschloßstraße in Hannover.
Fig. 2. Eisenbeschlag von
Alten Pöhlmann.

Meyer-ausgr.

