

Drahtseil-Wandwinde von 100 kg Tragkr. mit Sicherheitskurbel
v. Muth & Liebig, Leipzig

Fig. 1. 1:5

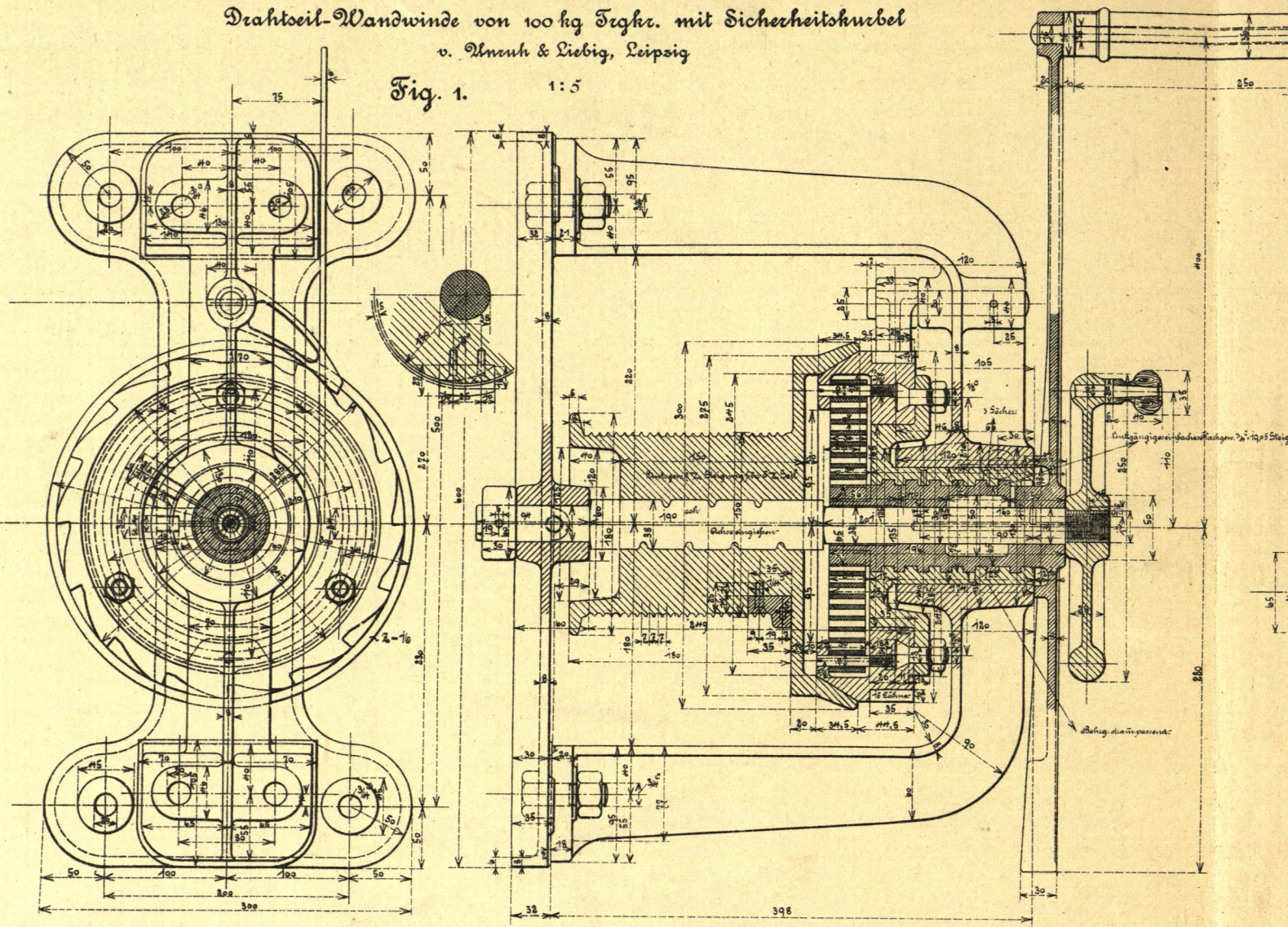

Ketten-Wandwinde von 1000 kg Tragkr.
v. Mohr & Federhaff, Mannheim
1:5

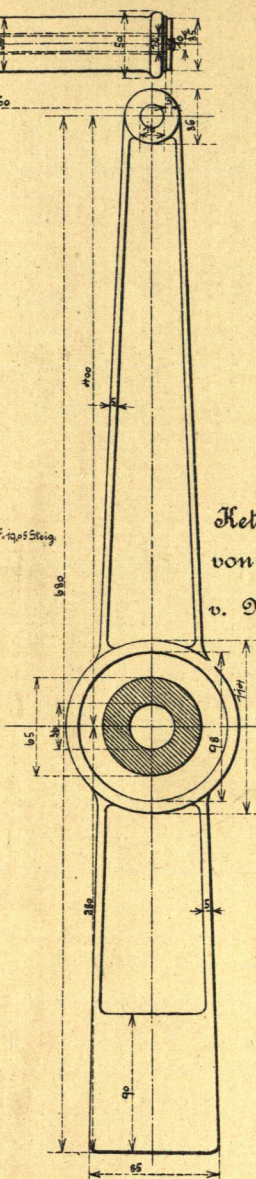
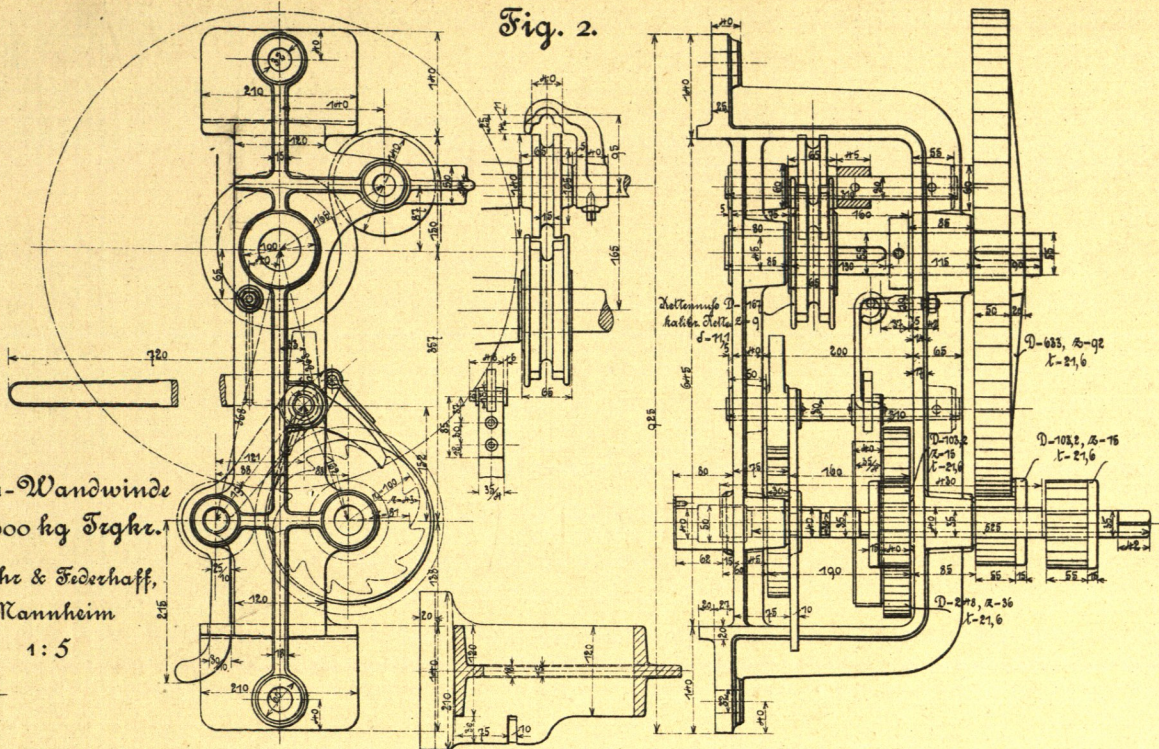

Fig. 2.



Kanaseil-Wandwinde von 600 kg Tragkr.
v. Mohr & Federhaff, Mannheim
1:5

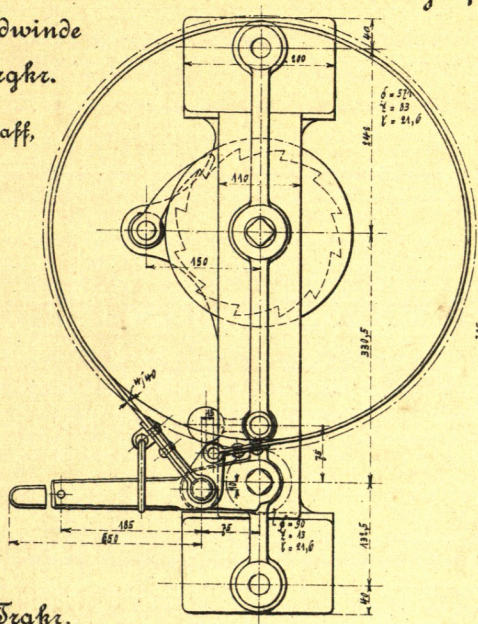
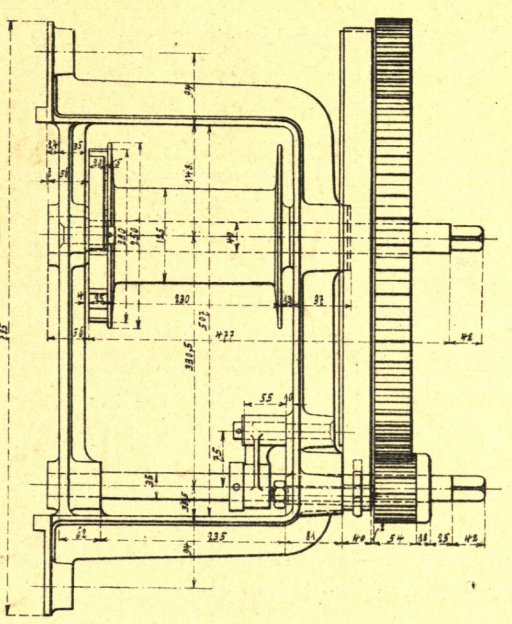
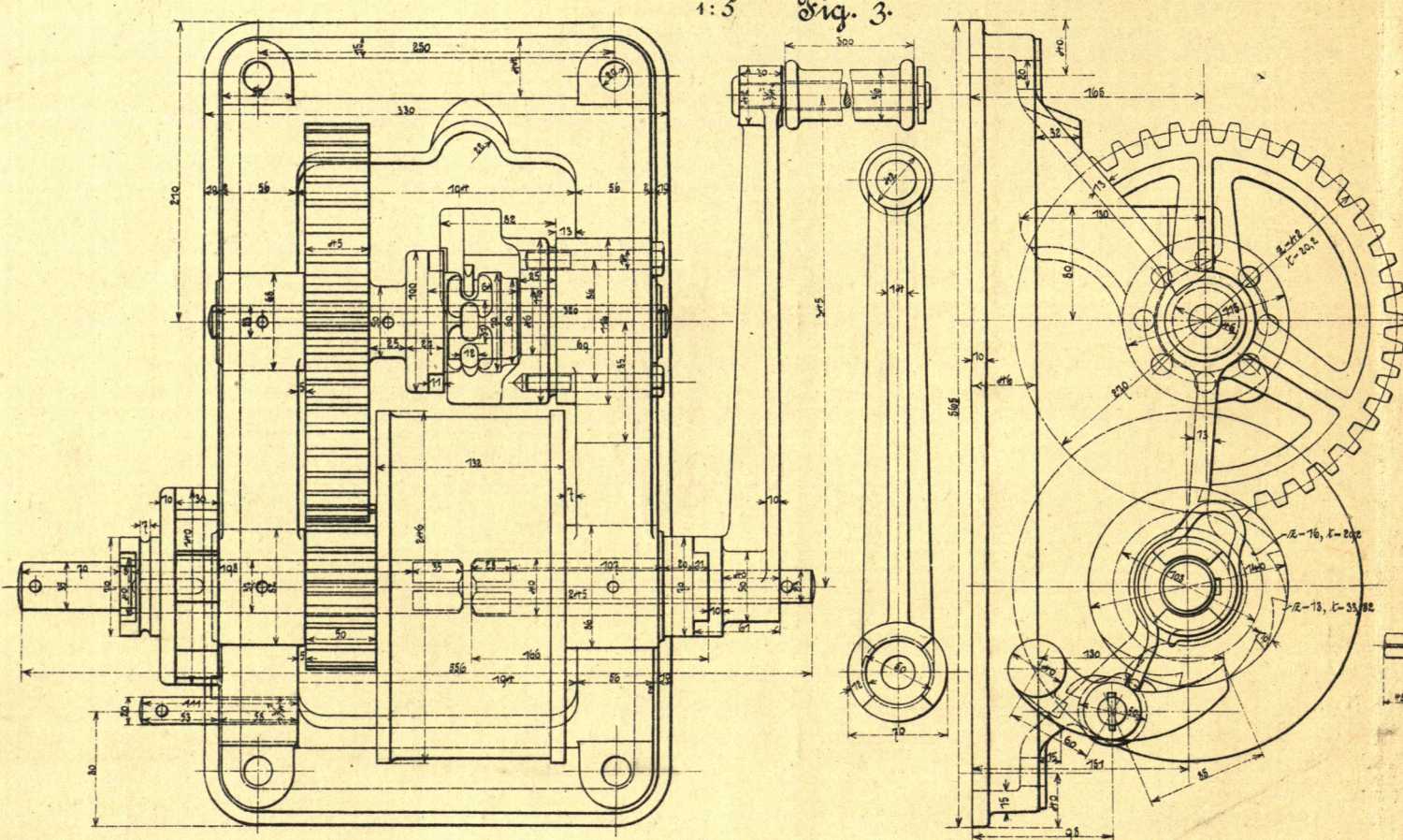

Fig. 4.



Ketten-Wandwinde von 300 kg Tragkr. mit Sicherheitskurbel
und Schleuderbremse
v. Buegler, Hansen & Co., Gotha

Fig. 3. 1:5



Kanaseil-Wandwinde von 1000 kg Tragkr.
v. Mohr & Federhaff, Mannheim
1:5

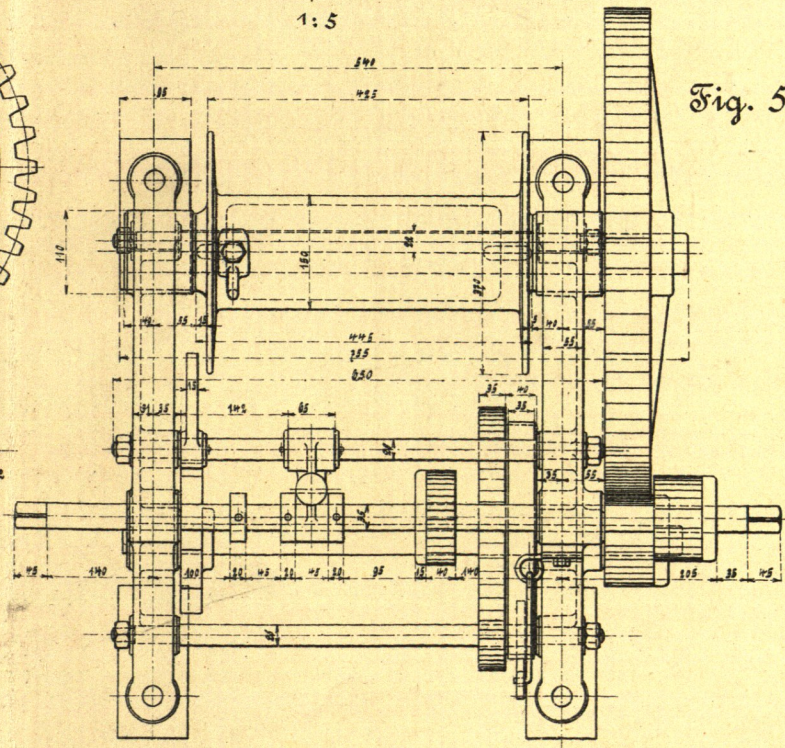
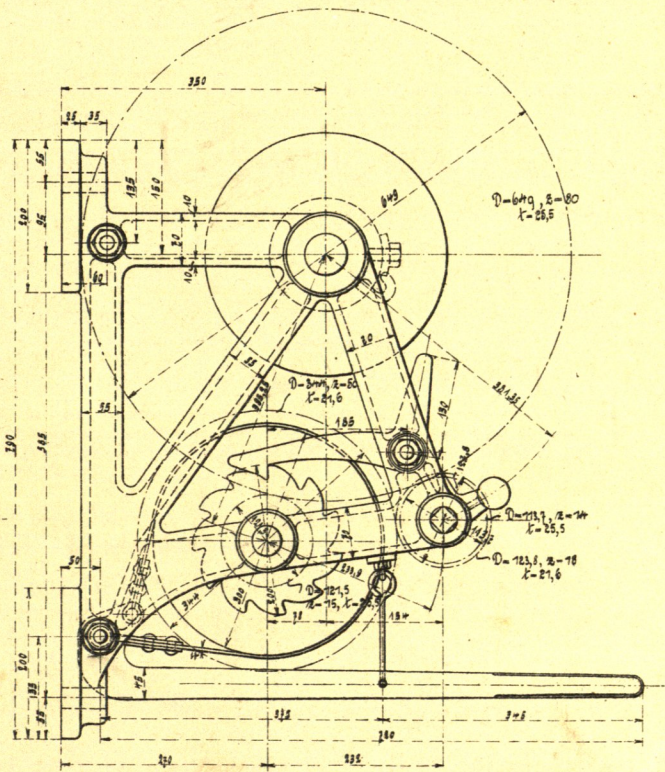

Fig. 5.



14 ca 50
17 ca 68
15 ca 56

19. Lh.
36 Wd